

HIGH-SPACE EUPHORIA



HIGH
SPACE

PATRICK TAYLOR



Contents

Euphoria	1
Prologue	2
The Altitude Bar: Your first time	3
Altitude Bar: Captain Pang <i>and the crew of the Dalliance</i>	4
Altitude Bar: Captain Geraght <i>and the crew of the Star</i>	5
Altitude Bar: Captain St. Cloud <i>and the crew of the Burden</i>	6
Euphoria Station: The Chapel	7
Euphoria Station: The U.R.C. Bureau	8
The Remnant stirs	9
Aftermath	10
Starship stat-blocks	11

(c) 2013, Patrick Taylor

Author: Patrick Taylor

Artwork: Joe Sweeney

Layout & Design: Joe Sweeney

Editing: Ray Duell

Euphoria

Game-in-a-can



Details:

Euphoria is a Game-in-a-Can scenario presented by Storyweaver Productions, and is an excellent way to start gaming in the setting of *The Lantern*, using the *High-Space* rules. This adventure is centered around the notorious Altitude Bar on Euphoria, the space-station which orbits above The Remnant - the unstable, broken planet once home to ancient civilizations and now the stalking ground of treasure seekers and artifact hunters alike! This module details the Altitude Bar and other sections of Euphoria, and provides NPC characters and starship descriptions to help kick-start your campaign.

The adventure is not linear in the way it progresses. Rather, it is a 'sandbox' in which your heroes will adventure. But there is a time constraint... inevitably, the Remnant will undergo a 'shift' that unearths a sizeable portion of new land, drawing scavengers and relic hunters like bees to honey!

This adventure requires the *High-Space* rule books, and the *Savage Worlds* core rules in order to play.

Legalese:

This game references the *Savage Worlds* game system, available from Pinnacle Entertainment Group at www.penguin.com. *Savage Worlds* and all associated logos and trademarks are copyrights of Pinnacle Entertainment Group. Used with permission. Pinnacle makes no representation or warranty as to the quality, viability, or suitability for purpose of this product.

Prologue

Fluff:

The public view-screen in the Altitude Bar showed the red and purple haze of the local nebula as a gorgeous backdrop to the Dalliance, as it slipped into its docking bay.

Inside the Dalliance, Captain Gerrad Pang was in a foul mood yet again. 'Why does that pre-pubescent bastard rock-humper always beat me to the Remnant? I swear the universe has put a curse on me!'

'Because you are both slow, and stupid,' Bonaparte spat back at him. 'I would not need all the time you take to prep for launch. Why all the systems checks? Are you a coward?'

'Shut up, you stupid computer. You are not even a real intelligence. You are artificial. What would you know? If the life support fails it is not you who will freeze to death!'

Not for the first time that day, Gerrad wished that he had enough capital to replace the starship's positronic core. Maybe he would have... if that young bastard didn't keep beating him to the best finds.

'Hurry up and dock already,' Gerrad continued. 'There's someone in the Altitude that I really need to speak to...'



The Altitude Bar: Your first time

Consider Phlebas...

Fluff:

The entry to the Altitude is a constantly-rearranging, holographic, neon gateway, which sometimes appears as a glowing circular iris, and at other times looks like the event horizon of a black hole, but it never looks the same way twice. The latest Video-Audio recordings, or 'Vauds,' are played around the walls and sometimes across the uniforms of the staff – depending on how much the bar is paid to promote each track – but they are muted enough not to detract from the fact that first and foremost the Altitude is a place of business. And the business of exploring the Remnant is always good! Hot-shot pilots, cybered mercs, and even scruffy explorers and pioneers fill the seats and talk of little else besides their next big find! Only one person stands apart from all the noise and action – one of the private booths near the entry is the domain of a solitary, young pilot, who watches the room with a weary gaze and keeps his drink close. Aside from his singular, glaring, downbeat presence, the Altitude is a good place to find whatever sort of action you seek.

Details:

Every space-station has a diverse range of bars to keep jaded flight crews amused for weeks of shore-leave, but only Euphoria has the Altitude. The Altitude is known to every starship crew in The Lantern as the place to go when looking for action, whether it is a contract for the Remnant or a quick pick-up on the Merc-list.

The Altitude is also home to Jebediah Kerm; the youngest - and most successful - scavenger working the Remnant. Kerm keeps a low profile, and it is a well kept secret that he has amassed a fortune over the years, safely locked away in major banks and stuffed inside old kit-bags. Kerm is more than lucky – a side-effect of working the Remnant is that he has been plagued by whispered voices, that rise to a babbling crescendo whenever a landslip is about to unearth more of the Remnant's secrets. Although he tries to block out the voices, he can't ignore them when they rise up. However, he has learned how to focus on their direction and get advanced warning of exactly where the next upheaval will occur on the Remnant's surface. Jebediah lives a life of quiet paranoia; he can sense when someone is trying to scam him and likewise when someone is being truly honest and friendly with him.

Plots:

- Jebediah wants the ship codes to the Dalliance. His sixth-sense tells him that Gerrad Pang is a violent man who would kill to know the secret of his success. When the day comes that Pang confronts him, Jebediah wants an ace up his sleeve – Kerm uses a light shuttle on his forays into the Remnant, and is well aware that his vessel is outgunned and outclassed by even the smallest starship. Kerm likes using the shuttle precisely because it is small and unobtrusive, but it means that he needs to take precautions such as this.
- On a recent venture onto the Remnant, Kerm was confronted by a crazed Pilgrim who tried to steal his shuttle to carry on his holy work. Regretfully, Jebediah was forced to kill him in self-defense, but he still feels bad about it. Kerm has learned that Sister Chastra, who tends the station's Chapel, has obtained a Rose Concession, and he would dearly love to obtain it to relieve his self-inflicted guilt, but he does not want to approach Chastra, in case she figures out why he wants it. If someone tries to befriend him he will share this sad story over drinks, and enquire if they would discretely obtain it for him.

Person:

Jebediah Kerm (Wildcard)

Human, Heroic, Beyond, Explorer

Attributes: Agility d6, Smarts d10, Spirit d8, Strength d6, Vigor d8

Skills: Knowledge (The Remnant) d8, Knowledge (Navigation) d8, Piloting (Starships) d6, Shooting d8, Streetwise d6, Survival (Terrestrial) d8

Charisma: -2, Pace: 6, Parry: 5, Toughness: 6, Equilibrium: +2

Special abilities: Remnant-affinity, Danger Sense, Tech-Implant (Handcannon)

Gear: Clamshell armor, Personal-shield, Optovisor, Shuttle XV-132 (see Starship Stat-blocks)

Notes: Despite his youthful appearance, Kerm has a reputation for being one of the best scavengers in the Remnant, an environment known for its general hostility! Kerm is a regular fixture at the Altitude Bar, where he drinks away his down-time... because it stops the voices in his head... the one's that tell him when the Remnant is active and about to reveal its latest secrets. Jebediah has no idea why this happens, only that it is always right.

Altitude Bar: Captain Pang and the crew of the Dalliance

High-tech Killers

Fluff:

Docked in the lowest berth of the stationary spindle arm, the Dalliance is a cargo vessel that displays all the tell-tale signs of living a dangerous life – laser burns on the fuselage, miscellaneous panel replacements, and discrete hard-points tucked away from plain sight. A search of the public records states the starship is registered to a Captain Gerrad Pang. Further data searches on that name list a variety of court appearances, including one that is blocked as it is currently under official investigation by the United Resources Corporation (U.R.C.).

Details:

Gerrad is a tyrant of a captain, and he elicits little trust from his crew, who have gravitated to the Dalliance as an escape from their various problems with the law, rather than because of their respect for Pang as a captain. Because the crew are all technically competent, Pang is willing to hire them at bargain rates and overlook any legal 'issues' that cloud their past. In his heart of hearts he believes that they, like him, are just victims of the injustices that the elite impose on hard working crews. Not that Pang is a hard worker; he just likes to believe that he is.

Pang and his crew stay near their starship when docked, for fear of running into other crews they have slighted or attacked in the past, and when they do venture on-shore they do so for a good reason and stick together. The crew of the Dalliance practice an extreme form of paranoia while they are docked, going to such extremes as maintaining a vacuum and zero-gravity in the umbilical tube that connects them with the station. They do not keep hard data connections open with any other network, and they keep their starship running on its own air and water supplies.

Plots:

- Gerrad is sick and tired of always being beaten to the Remnant by Jebediah Kerm and his silly little shuttle! Pang has a sub-dermal tracker that he wants someone to implant in Kerm without the boy knowing what is going on, so Gerrad can follow him on the next foray onto the Remnant. Gerrad will promise just about anything to get this done, but once it is accomplished he will start arguing that the original price was unfair and exorbitant and he refuses to pay whatever was agreed.
- Gerrad needs a new Positronic core for his ship – it is starting to hate him and develop an effete personality (starship AI's tend to model themselves on their captains.) The Positronic core of the Dalliance has recently gained a warped self-awareness, and has adopted the name 'Bonaparte' and begun making plans to replace Pang with someone more to its liking – perhaps one of the players would like to be the new captain? All they need to do first is take care of Pang!

Person:

Captain Gerrad Pang

Human, Veteran

Aspiring, Criminal

Attributes: Agility d8, Smarts d6, Spirit d4, Strength d6, Vigor d6

Skills: Gambling d6, Language (Dupherian) d6, Piloting (Starships) d6, Security d6, Shooting d6, Streetwise d8, Survival (Space) d8

Charisma: 0, Pace: 6, Parry: 4, Toughness: 5, Equilibrium: +1

Special abilities: Imp. Dodge, Gland Implant (Orexin A/B, Platelets)

Gear: Akrylar Flightsuit, Las-gun, Electrogloves, Dalliance (see Starship Stat-blocks)

Notes: Pang only cares about himself and the Dalliance, in that order. Everyone and everything else is useful only as long as it serves his purposes. Personality aside, he is a competent starship captain and pretty good judge of character.

Altitude Bar: Captain Geraght and the crew of the Star

The steel fist in the steel glove

Fluff:

The crack of discharging weapons echoes from the Recreational Shooting Range, and the tangy smell of ozone drifts around the adjoining corridors. A sign on the wall requires that shooters select their preferred target-type before they start firing – the range can display a selection of bulls-eye, silhouette, or photo-realistic targets.

The crew of the Star of Tomorrow lounge around what looks like a favorite table next to range number Six, drinking a vast number of assorted recreational beverages. However, closer inspection reveals that none of these are narcotic or depressants. Apparently Commander Ivan Geraght runs a tight ship on the Star, and although crew members are allowed to relax, they are required to maintain a state of travel-worthiness at all times.

Details:

Ivan is the Commander of the Star of Tomorrow, a 'demilitarized' frigate stationed at Euphoria in a clumsy but powerful attempt by the Armada to monitor new finds coming out of the Remnant. By the rules of Euphoria and the U.R.C., the Star is not supposed to carry spinal mounted weapons systems, but although the Spinal Lance on the ship is supposedly deactivated, it still makes a strong visible deterrent! Even though Ivan was officially mustered out of Armada, the Armada pays him a stipend to run his forays into the Remnant from Euphoria because it provides them a plausibly deniable operative in the area, and it keeps them up to date on the latest finds. During his tours of duty with Armada, Ivan saw several starship actions against blockade runners – the blockades may have been political setups but the fighting was real, and Ivan is a true combat veteran. Even without its Spinal Lance functioning, the Star is still a formidable opponent.

If anyone approaches the Recreational Shooting Range while the crew of the Star are present, they will at first be both cold and hostile towards them, only tempering their cool attitude if the newcomer can demonstrate some kind of martial prowess. If anyone persists in hanging around, Ivan will recognize that they just might have the qualities he needs to help him out with a few small problems...

Plots:

- Geraght has recently acquired the components to reactivate his starship's Spinal Lance, but none of his crew are rated to do the work. Geraght needs to hire a mercenary outfit to kidnap a particular tech specialist from one of the other ships at the Station... and then keep the kidnapping and subsequent repairs a secret...
- Ivan was once friends with local Chaplain Chastra Irena, but recently he has begun to suspect that that she had abused their friendship to further the influence of the CofC. He is not sure of the details, but has noticed that recent supply vessels have traded first with merchants that Chastra has developed good relationships with, and only then with the Star and other Armada vessels. Geraght knows that he is no good at cloak-and-dagger work, and will pay hard cash to anyone who can bring him proof that Chastra has been deliberately working against either himself or the Armada.

Person:

Commander Ivan Geraght

Human, Heroic, Militant, Soldier

Attributes: Agility d8, Smarts d6, Spirit d6, Strength d8, Vigor d8

Skills: Fighting d6, Knowledge (Armada) d4, Knowledge (Navigation) d8, Notice d8, Shooting d6, Survival (t/Terrestrial) d10, Charisma: 0, Pace: 6, Parry: 5, Toughness: 6, Equilibrium: +2

Special abilities: Imp. Dodge, Natural Leader, Sweep, Tech-Implant (Plasma sword).

Gear: Akrylar flightsuit, Multivisor, Las-gun, Star of Tomorrow (see Starship Stat-blocks)

Notes: Ivan wears a surplus Armada flight suit, with a Sturminan fleet badge, and he proudly tells people of his allegiance to Sturm. He has seen combat, both personal and starship, and considers himself fortunate to still be amongst the living. He hopes to continue that good fortune through good planning.

Altitude Bar: Captain St. Cloud and the crew of the Burden

Expensive taste in starships

Fluff:

The Burden of Usury is a customized slimline class starship, sleek and atmospheric-capable, and sporting the latest color schemes and hull materials fashionable in the Dupheris system. There is barely a scratch on the hull, and it looks like whomever captains her either takes excellent care of the ship or simply has not had her for long.

A basic search of the U.R.C. port registry shows that the Burden is owned by Amber St.Cloud, registered out of Alecto, Dupheris. The need for a permanent merchant vessel in the Remnant is not immediately obvious, but if the St.Cloud family business reputation is anything to go by, there will be a good reason for the Burden's presence here.

Details:

The crew of the Burden stay together in a tight knot when frequenting station bars and clubs, including visits to the Altitude, and they avoid drawing attention to themselves. Their uniforms are based on recent designs from Alecto, and bear a rough approximation of the St.Cloud family crest on the shoulder.

The registered captain of the Burden is Amber St.Cloud, a distant heir to the St.Cloud fortune and known as a fair and accomplished captain, trader and a tough negotiator. However, if the news reports are true, her success on the Remnant has been quite limited. While on Euphoria, Amber always has an escort of crew when she moves about. She is at the Remnant to make her fortune, and at the same time to hunt down and kill Captain Gerrad Pang of the Dalliance; the man she believes she believes responsible for the death of her father. She is unsure if Pang knows of her plans, and will treat over-friendly strangers as potential threats, but when she senses that someone really wants to talk business she will become more relaxed. Amber is a Wildcard, with a knack for good leadership, although her quest for revenge can blind her better judgement.

Plots:

- The Burden has the best observational systems of any starship in the system, but Amber knows that the Euphoria techs are consistently beaten at predicting the next upheaval by Jebediah Kerm. Whoever can work out the young explorer's advantage and neutralize it will be offered a high percentage of St. Cloud's first salable find from the next site she reaches ahead of Kern. If she sees a likely crew enter the Altitude, she will post an anonymous notice looking for 'covert field-workers for short term contract.'
- Amber harbors a deep grudge against Gerrad Pang, the Captain of the Dalliance. Stories passed down through her family claim that it was his ship, most likely with Pang as the captain, which attacked and killed her father during an illegal blockade of the third moon of Saturine four years ago. Anyone who ruins Pang will be owed a great debt by the St. Cloud family.

Person:

Amber St.Cloud (Wildcard)

Human, Veteran, Aristocrat, Entrepreneur

Attributes: Agility d6, Smarts d12, Spirit d10, Strength d4, Vigor d6

Skills: Notice d10, Knowledge (Inter-stellar Trade) d8, Persuasion d6, Pilot d8, Shooting d6

Charisma: 2, Pace: 6, Parry: 4, Toughness: 5, Equilibrium: +1

Special abilities: Level- Headed, Natural Leader, Fervor, Hold the Line!, Synergy (+1 tech/weapon use)

Gear: Aesir Mark-I power-assisted-armor (Armor +4, *+1 to attributes), Personal-shield, Neutron-gun, starship Burden of Usury (see Starship Stat-blocks)

Notes: Amber St.Cloud is a distant heir to the St.Cloud fortune, who managed to acquire a starship from the family company although it put her into great debt. She now hunts the Remnant for a find that will solve all her financial problems, and for her father's killer.

Euphoria Station: The Chapel

The tranquil Torian

Fluff:

Every station and almost every ship has a Chapel, and the one on Euphoria is an excellent example of how they should be done. Triangular shapes are prominent, reflecting the ethos of the Triptych, the three pillars of religious society – Souls, Judgment, and the Afterlife. The back wall, above the altar and pulpit, is dominated by a holographic display of The Lantern nebula, the bright reds muted to less glaring colors, and the imagery it evokes is one of a ‘stellar womb’ that is comforting – quite different from the image of a ‘galactic oddball’ more common to the daily media. Uplifting classical music plays from a mock pipe-organ that looks just a little too big for a Chapel of this modest size.

Crews are found worshipping in the Chapel at all hours of the day-night cycle to which Euphoria adheres, because most newly arrived and short-stay starships tend to run on their own internal clocks, and waking and sleeping shifts. However, the advertised Chaplain’s hours are early morning, noon, and the evening if anyone is looking for confession, or even for a Concession.

Details:

Chaplain Chastra Irena ministers to whomever wishes to visit the Chapel, and her calm manner invokes an atmosphere of quiet reflection, peace, and tranquillity. Chastra is young compared to most Chaplains, especially for such a prominent posting as Euphoria, but she has an air of quiet confidence about her. Unknown to her superiors in the CofC, Chastra is a ‘Pilgrim’ who is dedicated to carrying the holy word of the Triptych to the ends of creation. Otherwise, she plays the role of a local Chaplain very well – an easy listener who is light on advice. Chastra used to operate a clandestine ‘cell’ with Brother Marco, a fellow Pilgrim, but when he failed to return from his last trip to the Remnant, the burden of the Pilgrimage fell to Chaplain Chastra alone. She will keep her eyes and ears open, hoping to locate another Pilgrim who can share the road.

Plots:

- When Brother Marco died on the last exploration flight to the Remnant, it left Chastra as the last Pilgrim on the station. She needs to find and convince a starship crew to take her on the next flight to the Remnant in order to bring the holy word to this part of creation – she will frequent the Altitude Bar claiming that she wants to search for Brother Marco, but in reality she believes that he died on the Remnant, and now all she wants is to be able to Pilgrimage as far into the Remnant as she can when the next upheaval occurs. However, Chastra is not suicidal, and plans on returning to Euphoria by any means possible.
- Chastra was injured a decade ago in a freak driving accident while working as a field missionary on Yostra. She was healed at an Armada hospital, which gave her military-grade optics to replace her damaged eyes. The optics need replacing, and the only place to get them from is the Armada – but she has butted heads with the military too often in recent times for them to do her any further favors. If someone could acquire her a new set of optics, Chastra has a single Concession (Rose) that she obtained through the Pilgrims which could be used as payment.

The Rose Concession

The Rose Concession is the most argued over Concession granted by the CofC; it grants absolution for a murder, committed or planned. Rose Concessions are only created on the offering of a sacred white rose, grown at a high altitude on the slopes of Mount Florens, the second highest peak on the planet Parity. The roses are grown only by a special sect of the CofC, and cost 100,000 credits each.

Person:

Chaplain Chastra Irena

Human (Synthetic), Seasoned, Theocrat, Criminal

Attributes: Agility d6, Smarts d4, Spirit d10, Strength d10, Vigor d6

Skills: Knowledge (Theology) d8, Persuade d10, Psychiatry d8, Streetwise d8, Taunt d8

Charisma: 2, Pace: 6, Parry: 2, Toughness: 5, Equilibrium: +1

Special abilities: Synthetic Edges (Painless, Mechanical strength)

Gear: Rose Concession

Notes: Chastra is understanding and caring, except towards people and situations that get in the way of her holy duty to Pilgrimage. When required, she can deploy both her physical strength and her natural charisma as deadly weapons.

Euphoria Station: The U.R.C. Bureau

Bureaucracy at the speed of light!

Fluff:

At the heart of every mining operation in every system, and on every planet or station, is a U.R.C. bureau. These ubiquitous offices are all the same, uniform, slate-grey color, except for the showcases of local minerals – which in the case of the office for the Occassus system is a lump of dull asteroidal iron. Equally dull and uninspiring ‘virtual’ staff pretend to shuffle data files and sheets around, and strive to make the perfect cup of coffee every fifteen minutes.

The real, physical occupant of the large, brass-and-glass-walled executive suite, taking up almost the full side of the office with a view of the stars, talks loudly and pointedly into his comm-link although the actual words are mercifully blocked by a privacy filter. The brass plaque next to the door proclaims that the office belongs to ‘Delton Keanes, URC Bureau Director, Euphoria.’

Details:

The U.R.C. bureau in Euphoria has been a political sore-point for decades. Technically there is no mining on the Remnant, so the U.R.C. need not be on Euphoria. The U.R.C. maintains that there is asteroid mining in the system, and that Euphoria is a better option than building a space structure or operating only out of starships in the system. The U.R.C. only obtained offices on Euphoria after threatening legal action against the consortium that owns the station. As a supporter of the Commercials, Keanes was appointed to the role of local bureau manager as a political foil to the strong Armada influence throughout the organization, instilled by its current Director. Armada vessels entering the system, including ‘demilitarized’ starships like the Star of Tomorrow, are slow to transmit information to the U.R.C. and sometimes forget entirely, which is a continual source of friction!

Plots:

- Keanes is sick of the Armada’s attitude, and has decided to use some of his private resources, which are substantial, to hire a covert group to infiltrate the Star of Tomorrow and insert a purpose built relay circuit into their computer – which will store all communications to and from the Star in an unencrypted format, and upload it to a third-party computer each time she docks. So far he has not found anyone he deems capable of completing this mission. When he does he will post an anonymous notice in the Merc List looking for a ‘grey-ops technical crew’ and make sure that they see it.
- The U.R.C. knows that the statistical frequency with which Jebediah Kerm is able to launch his shuttle for the Remnant before any other player in the scavenging game, right at the time of an upsurge, is improbably high! Keanes is convinced that Kerm has a way of predicting when upheavals will occur on the Remnant, and he will pay to get it. He suspects that Kerm found some kind of lost technology on one of his early trips to the Remnant, but he has, as yet, been unable to locate it. This is a job well suited for an inquisitive starship crew.

Person:

Delton Keanes

Human, Veteran, Technocrat, Qualified

Attributes: Agility d4, Smarts d8, Spirit d8, Strength d4, Vigor d6

Skills: Investigation d6, Knowledge (U.R.C. operations) d8, Notice d6, Persuade d8, Language (Dupherian) d6

Charisma: 0, Pace: 6, Parry: 2, Toughness: 5, Equilibrium: -1

Special abilities: Synergy (+1 tech/weapon use), Tech-Implant (Translator),

Gear: Personal-shield, Civilian personal flyer

Notes: Keanes is a quiet but ardent supporter of the Commercials. He is vexed that his influence is not as great as it could be, due to the limited mining in the Occassus system, and will use less-than-savory means to increase his influence whenever he believes he can get away with it.

The Remnant stirs

The action scene!

Details:

Recent comet activity through the Remnant has unsettled the surface of the planetoid, and it is ready to shift again. Anyone watching Jebediah Kerm will notice that he suddenly gets twitchy and leaves the bar, acting too drunk to walk but quickly sobering up once he is away from the bar area. This happens about ten minutes before there is a general announcement by the Euphoria's sensor operators that another shift in the surface has resulted in sizable new mass being driven to the surface, with a "79% chance of remaining viable for landing for the next 4 hours."

Plots:

- Jebediah will make his way quickly to his shuttle as soon as he leaves the Altitude Bar. He will not launch until he hears the general announcement, even if it means another starship might launch before he does – he is too clever and careful about the way he operates to provide an obvious give-away that he has an edge. If he senses that he is being followed by someone with dangerous intent then he keeps his weapons handy, and will seal the next bulkhead he comes across, blasting the control mechanism after he passes through.
- Gerrad Pang and his crew will be spread between their ship and the various bars in Euphoria. Before the general announcement sounds they will attempt to converge at the Dalliance. Pang will not wait for latecomers before he takes off for the Remnant – he is very unsympathetic towards his crew. If any of the crew of the Dalliance are followed or waylaid on the way to their starship, they will not hesitate to draw weapons and shoot first.
- Chaplain Chastra Irena will usually be found around the Chapel during the day-cycle on Euphoria, and she has a rectory which can be reached via a locked bulkhead from the rear of the Chapel. However, when not ministering she is likely to be found in the bars around the station, carousing and getting to know the crews. When the general alert goes out, she will approach all the crews that are present, pleading that they must help her to look for Brother Marco. If that fails she will try to stow-away on a starship going to the Remnant – she is fanatical in her beliefs as a Pilgrim, and will resort to pleas, and then threats of violence, in order to get there. If discovered as a stow-away, anyone with a knowledge of CofC Theology stands a chance of persuading her from doing something suicidal if her pilgrimage is thwarted.
- Ivan Geraght and the crew of the Star of Tomorrow spend most of their shore-leave at the recreational shooting range. When a general alarm goes off they make an ordered dash for their starship. If Ivan believes he has the time he will make a side-trip to the Chapel to see if there is any opportunity provided by the chaos to confront Chastra Irena alone – and possibly even to kidnap her! The crew of the Star don't take kindly to being watched at any time, but they will not act against 'spies' until they are outside the docking-zone of the Euphoria, at which point they will consider opening fire on anyone they consider a threat. The Star typically does not land on the Remnant, but instead sends down a shuttle, so that it can maintain combat stations at all times. Geraght always considers ambushing other starships that he has suspected of making important finds in the Remnant, but to date has not followed through with this type of piracy.
- Amber St.Cloud will wait patiently for all the other ships to depart for the Remnant, citing engine problems, because she wants to use the confusion of the upheaval to take her revenge on Pang (assuming that he has not been dealt with earlier). The Burden will approach the Remnant, appearing to land near the Dalliance. On approach, she will deliberately overload and jettison one of the Burden's X-Ray lasers – its explosion will knock out all communications and sensors (permitting visual targeting only) for several rounds, simultaneous to the Burden attacking the Dalliance. If Amber has picked up communications by Gerrad from the surface of the Remnant, then she will wait until he is back inside his ship before attacking. Her alibi later in a U.R.C. court will be to claim that it was an accident and that her technical troubles had obviously been more extensive than first thought... the Point Deefense Array that had to be ejected must have struck the Dalliance... so sad...
- After the general announcement, Delton Keanes will observe all starship traffic very carefully. Jebediah Kerm's small shuttle will be difficult to isolate amongst all the rush of activity, and will go completely off the sensors if Amber St.Cloud's plan comes to fruition. After all the starships and shuttles have left, Keanes will break into Kerm's residence on Euphoria and plant several bugging devices which he has sourced from the Armada. Keanes will also demand a U.R.C. customs inspection of any vessel that showed an interest in Kerm, sending a U.R.C. shuttle to stop and search them in the general space lanes between Euphoria and the Remnant. While technically legal, this is against the spirit of the U.R.C. charter, as exploration of the Remnant is not counted as 'mining'. Afterwards, if he has identified an enemy of Kerm's, he will make a personal trip to negotiate a deal that will benefit both himself and Kerm's enemies...

Aftermath

Where to next?

This Game-in-a-Can was designed to showcase the idea that making a living (and a fortune?) in the Remnant is an interesting, unstable, and dangerous lifestyle suited to those who crave adventure!

However, getting to the Remnant is only half the fun. The surface of the Remnant is unlike anything your players are used to in a sci-fi setting...

Imagine swirling poisonous mists whipping through ancient stone columns embedded with the degraded remains of advanced computer control circuits.

The light from the Occassus suns is harsh and glaring due to the lack of an atmosphere, and at times the uplifted and titled landscape makes the world appear upside down.

The ground literally hums and vibrates as fractured tectonic plates grate against each other deep below the surface crust, and once they start shifting there are literally only moments left in which to safely lift off.

The splintered shapes of the recent wreckage of other ships serves as a startling reminder of the dangers, and crews are just as likely to stumble over the remains of a dead scavenger as they are an ancient race.

Sometimes what the planet brings to the surface isn't totally destroyed. Whole rooms, even passageways to entire sealed buildings, have been known to emerge and remain on the surface for seemingly random periods of time before being dragged back under.

The desperation and greed of those drawn to the Remnant is legendary, and a successful find almost always concludes with a fight to get it to a buyer on Euphoria or in another system (see 'Into the Remnant' and 'The Artifact and the Aeternaeánimam' upcoming releases.)'

There are also more mundane matters that can be just as involving for players...

By the end of the game, Amber St.Cloud will likely need a programmer to change the ships log on the Burden of Usury as part of her alibi for attacking the Dalliance.

Jebediah Kerm will be as paranoid as ever and willing to go to extremes to protect his secret. He will inevitably find out if the players helped Delton Keanes to surveil him, and will arrange a suitable revenge. Remember that he has resources and reclaimed alien technology he can draw upon, although his revenge will not be lethal as he may have further need of your heroe.

There are so many possibilities in this Game-in-a-Can, even forgetting for a moment what might happen on the Remnant, that it is unlikely that the players will exhaust them all in one game, and Euphoria and the Remnant will remain a focus for your campaign for quite a while. Eventually the players, or another group, should unearth something so significant that it naturally leads to the next stage in the campaign... Remember to keep watching the Storyweaver website for more releases for High Space/The Lantern.

Starship stat-blocks

Shuttle XV-132 (Jebediah Kerm's shuttle)

Shuttle, Explorer

Attributes: Maneuver d8, Computer d4, FTL n/a, Displacement d4, Quality d12

Pace: 17, Toughness: 8

Special abilities:

- No FTL core
- Shock pods (+1 Vigor when maneuvering)
- Luggage
- Overdrive
- Lifepods
- Non-Reactive Surface (-2 versus scans)
- EC suite

Weapons:

- Point-Defense Array x 2

The Dalliance

Sprint Trader, Warship

Attributes: Maneuver d6, Computer d6, FTL d8, Displacement d8, Quality d6

Pace: 11, Toughness: 5

Special abilities:

- Bad Reputation
- Positronic core (aka 'Napoleon')
- Expert Skills (Shooting +2)
- Cargo Container
- Armory
- Lifepods
- Docking-point

Weapons:

- PDA lasers x 2
- Quantum Lock; String-torpedoes x 2

Star of Tomorrow

De-Militarized Frigate, Warship

Attributes: Maneuver d4, Computer d4, FTL d6, Displacement d10, Quality d8

Pace: 15, Toughness: 6

Special abilities:

- Non-Atmospheric
- Armory
- Security Suite
- Landing-bay (for Displacement d4 starships and shuttles)
- ECM Suite
- Reactive Armor

Weapons:

- Spinal Lance (inoperative?)
- X-Ray lasers x 4
- Quantum Lock; String-torpedoes x 4

Burden of Usury

Cargo Carrier, Liner

Attributes: Maneuver d4, Computer d6, FTL d6, Displacement d10, Quality d10

Pace: 20, Toughness: 7

Special abilities:

- Limited-arc (Quantum Lock; forwards)
- Positronic core (aka 'Zephyr')
- Expert Skills (Notice +2)
- Bulk Storage
- Fluid Storage
- Guest Accommodation
- Lifepods
- Failsafe
- Docking-point
- Tempest Shielding
- Nanomedbay

Weapons:

- PDA lasers x 4
- Quantum Lock; String-torpedoes x 5

Euphoria: Core 1

"Altitude Bar Arm"

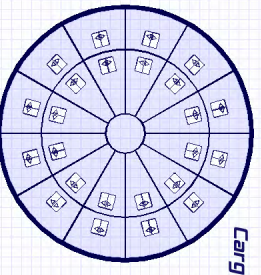
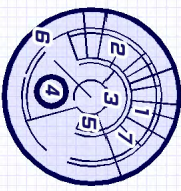
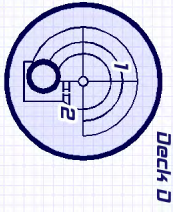
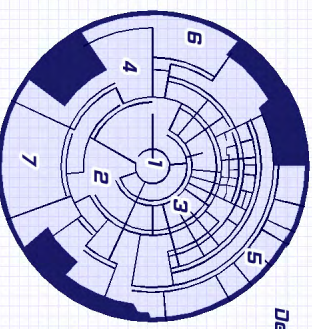
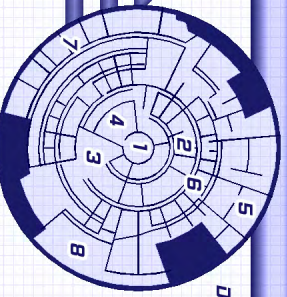
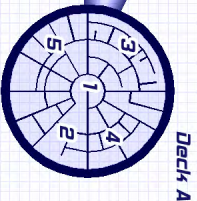
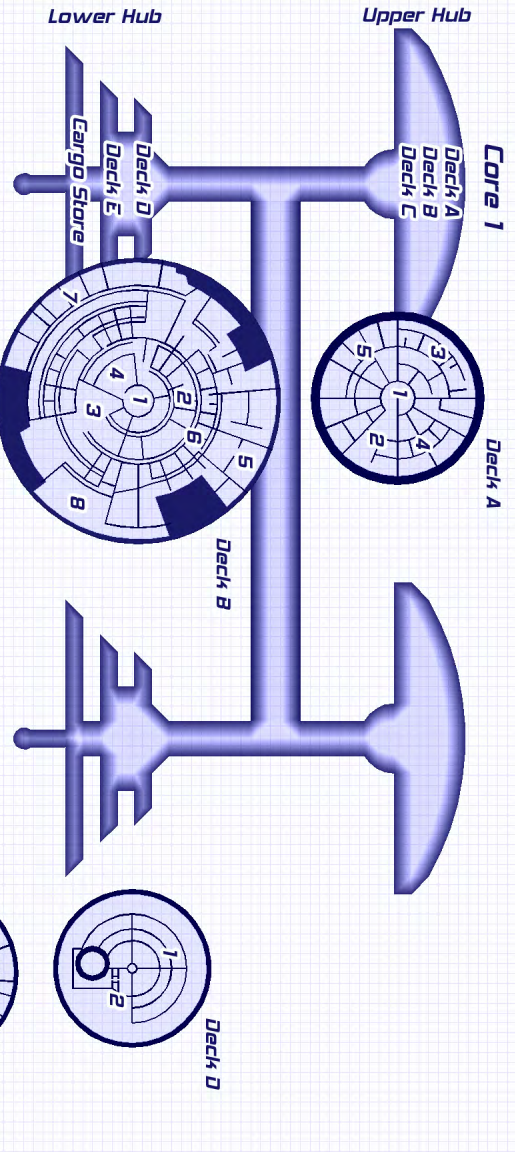

Deck A

1. Altitude: Bar Area
2. Altitude: Catering
3. Rental Habs
4. Short-time Rooms
5. Staff Accommodation

Deck D

1. Stores
2. Reactor Control

Deck B

1. Altitude: Bar Area
2. Altitude: Private Rooms
3. Altitude: Sports Bar
4. Altitude: Holo Entertainment
5. Shooting Range
6. Short Time Rooms
7. Rental Habs
8. Ship Dock 126

Deck E

1. Facility Accommodation
2. Management Staterooms
3. Admin & Coms
4. Reactor
5. Armory
6. Observation Deck
7. Brig

Deck C

1. Altitude: Main Entrance
2. Altitude: Gaming Lounge
3. Altitude: Business Lounge
4. Torian Chapel
5. Rental Habs
6. Ship Dock 12H
7. Ship Dock 12I



The Dalliance

Hawk Class

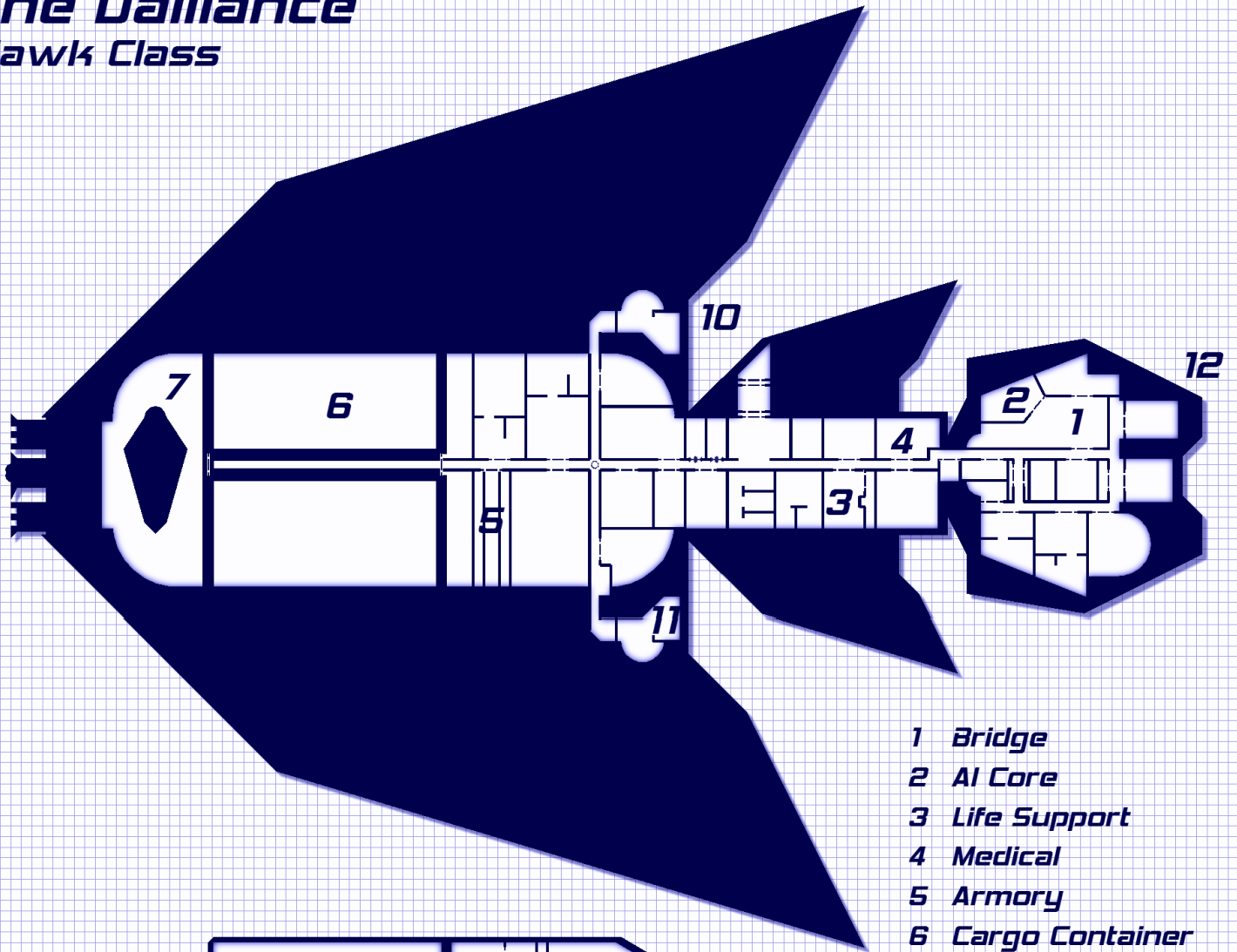

- 1 *Bridge*
- 2 *AI Core*
- 3 *Life Support*
- 4 *Medical*
- 5 *Armory*
- 6 *Cargo Container*
- 7 *Lifepod Bay*
- 8 *Crew Quarters*
- 9 *Mess*
- 10 *Laser A*
- 11 *Laser B*
- 12 *Torpedo Control*

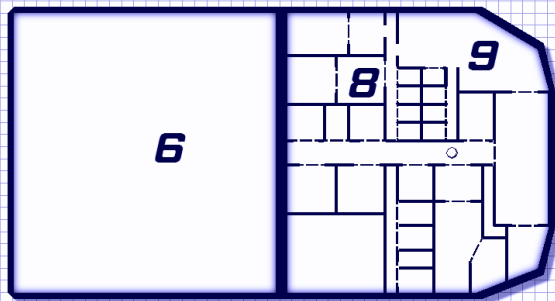

Burden of Usury

Longhaul Class

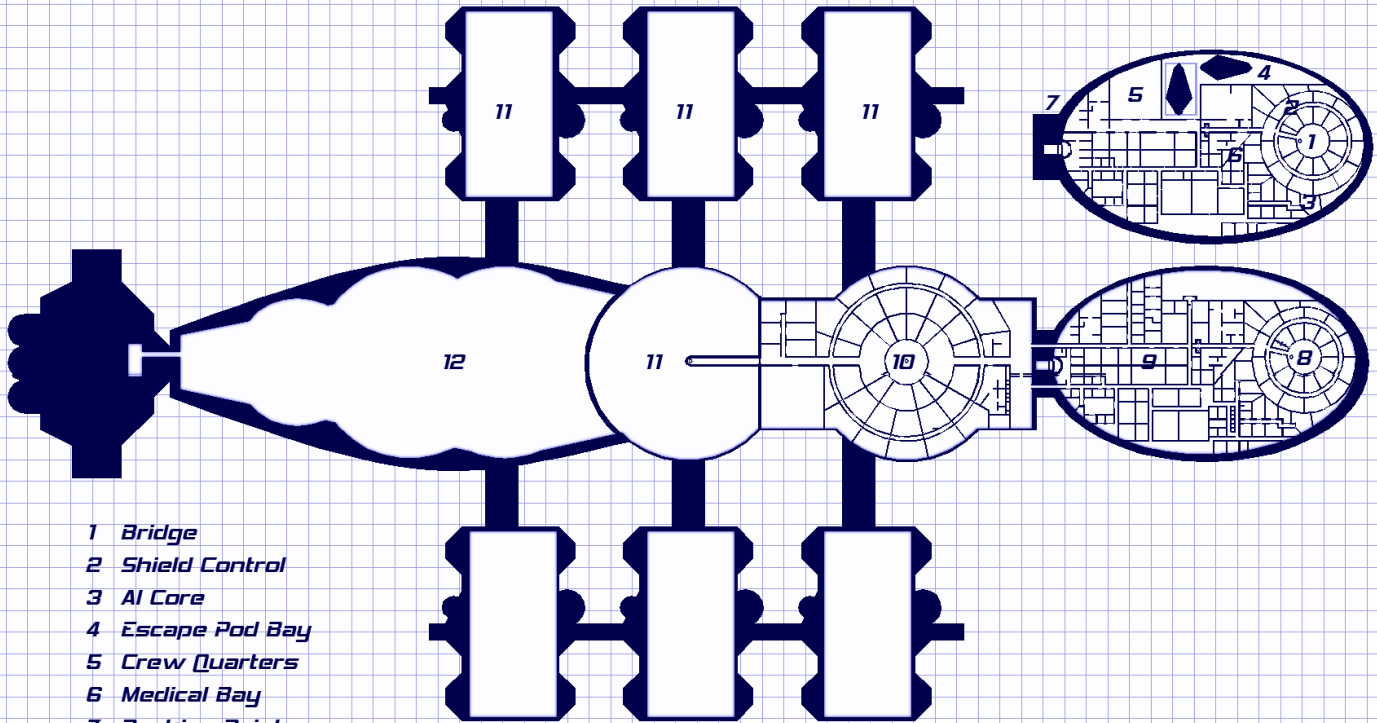
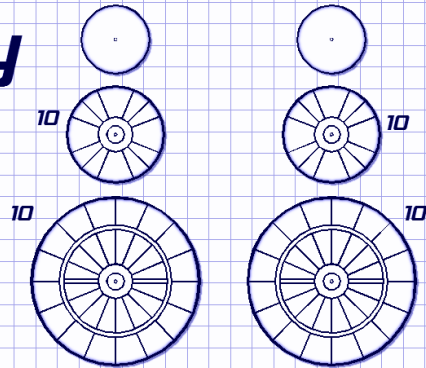

- 1 Bridge
- 2 Shield Control
- 3 AI Core
- 4 Escape Pod Bay
- 5 Crew Quarters
- 6 Medical Bay
- 7 Docking Point
- 8 Mess Hall
- 9 Crew Quarters
- 10 Passenger Accomodation
- 11 Bulk Storage
- 12 Fluid Storage

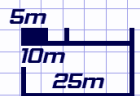
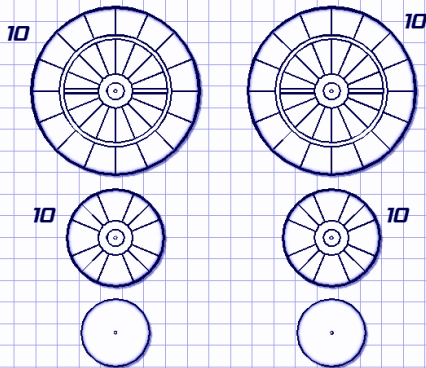

Star of Tomorrow

Sunquake Class

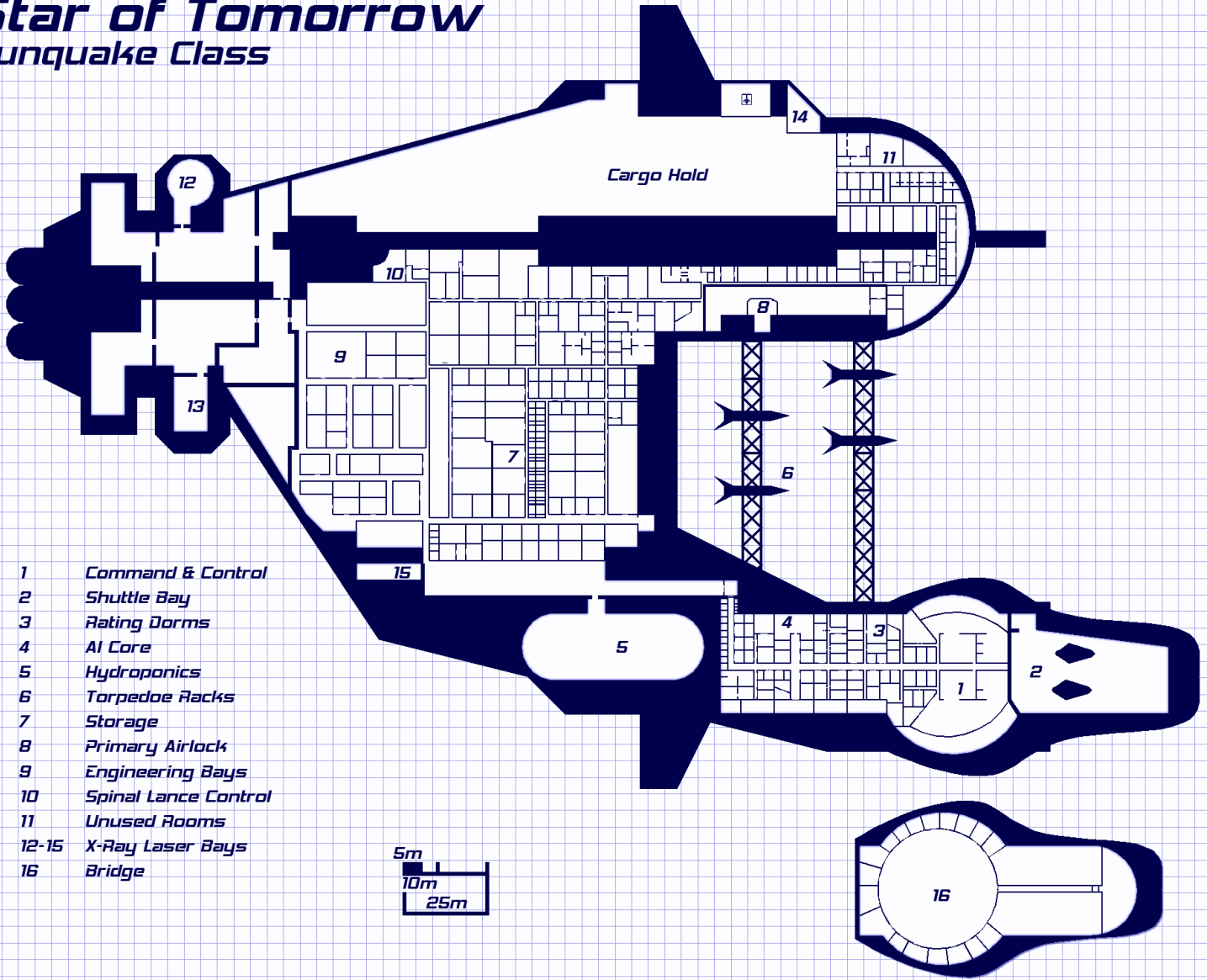

- 1 *Command & Control*
- 2 *Shuttle Bay*
- 3 *Rating Dorms*
- 4 *AI Core*
- 5 *Hydroponics*
- 6 *Torpedoe Racks*
- 7 *Storage*
- 8 *Primary Airlock*
- 9 *Engineering Bays*
- 10 *Spinal Lance Control*
- 11 *Unused Rooms*
- 12-15 *X-Ray Laser Bays*
- 16 *Bridge*

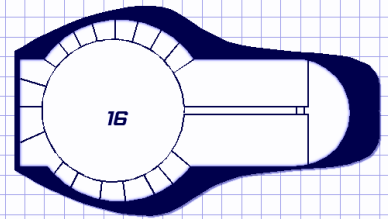
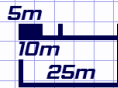

Battlemaps

Bar Entrance

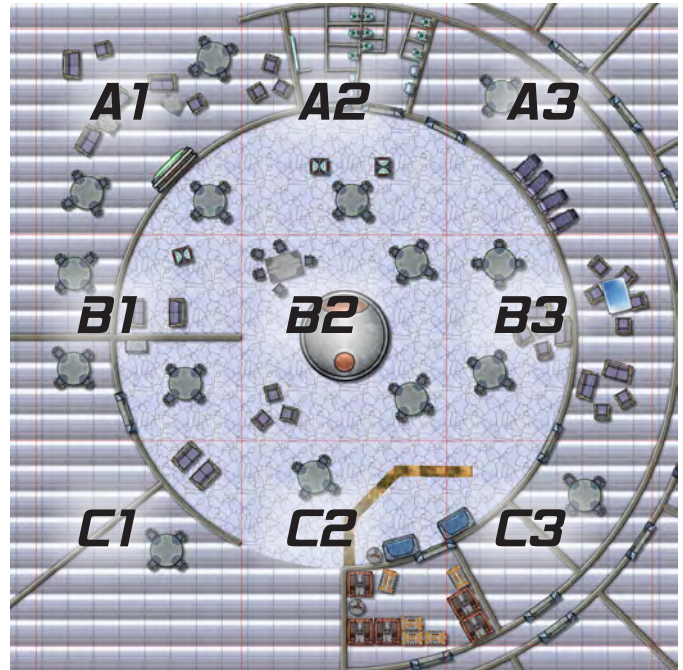

Chapel

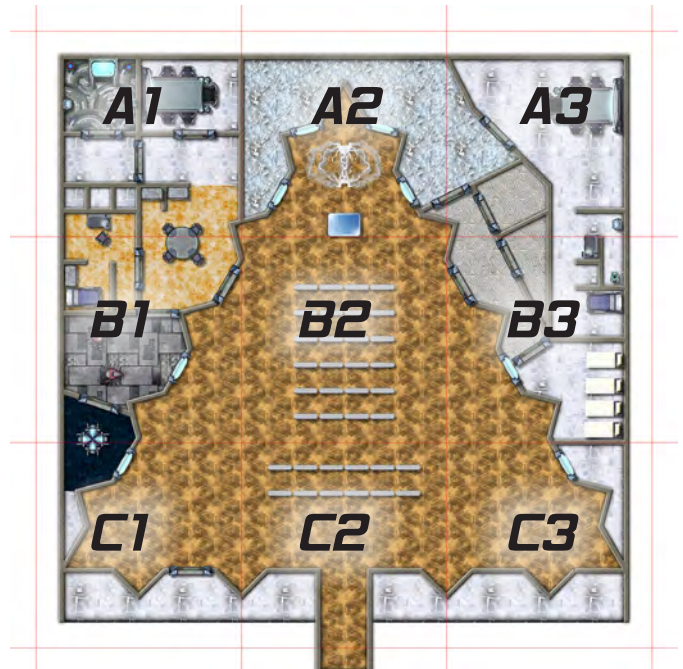

Bar A1

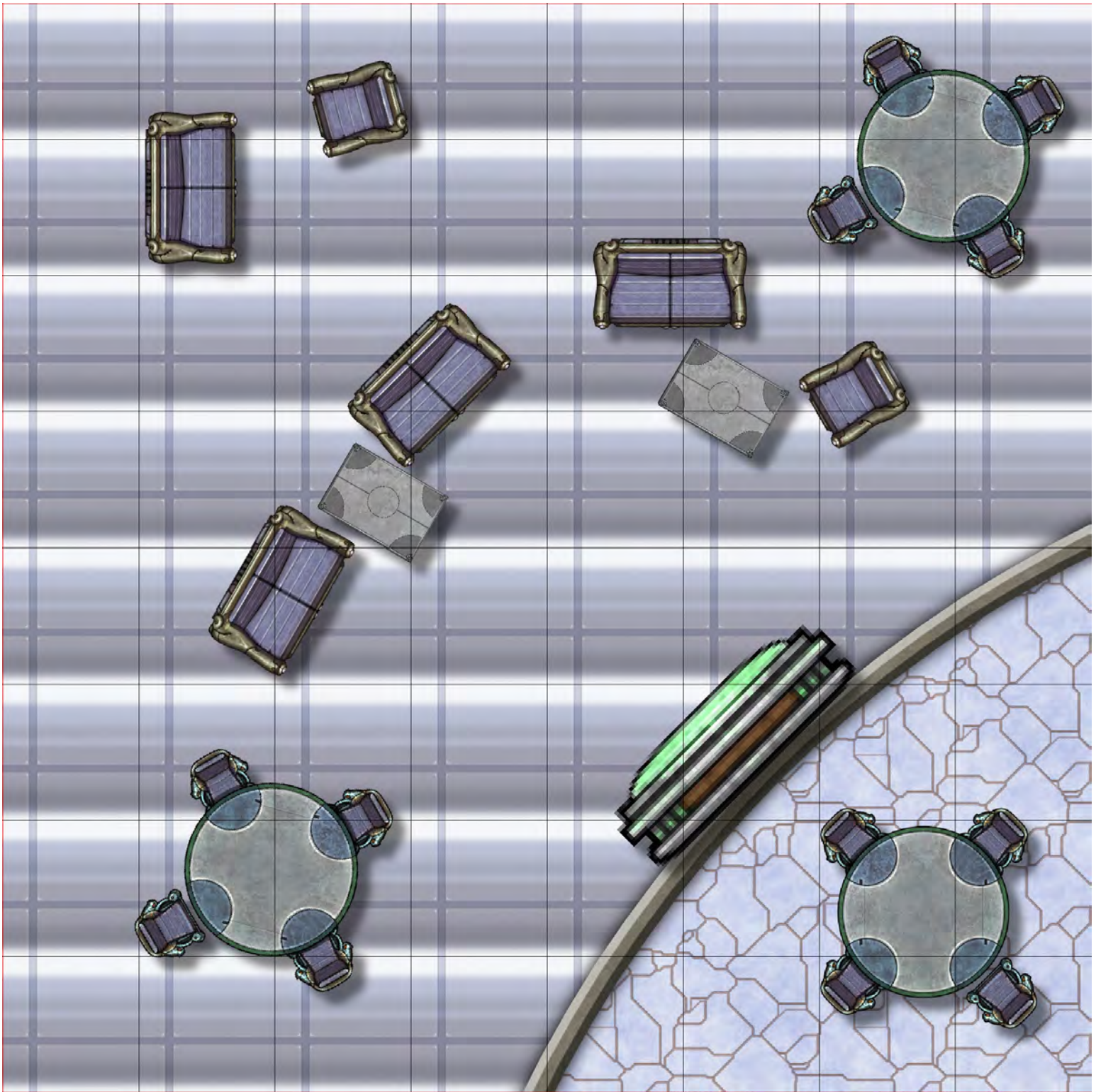

Bar A2

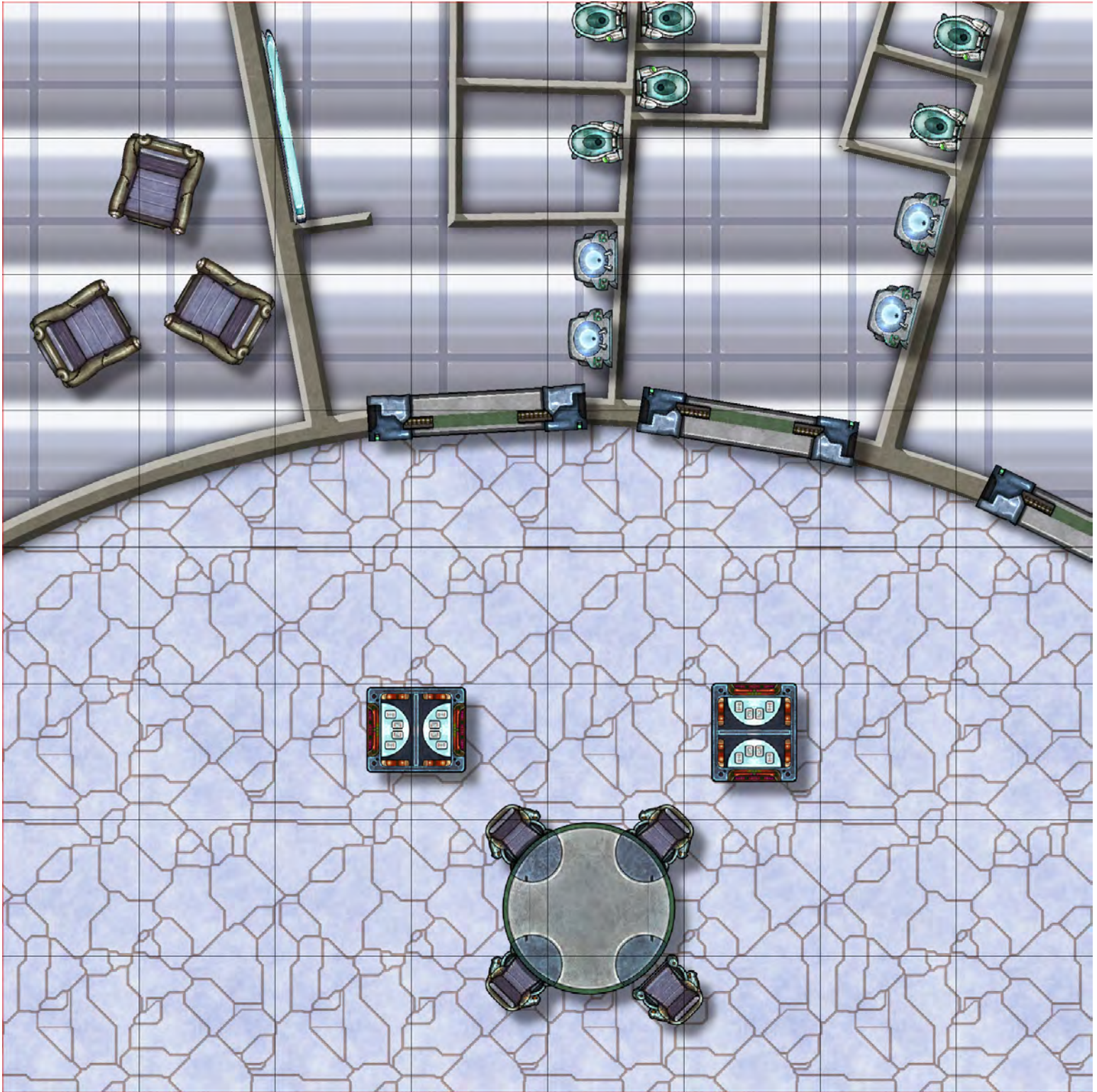

Bar A3

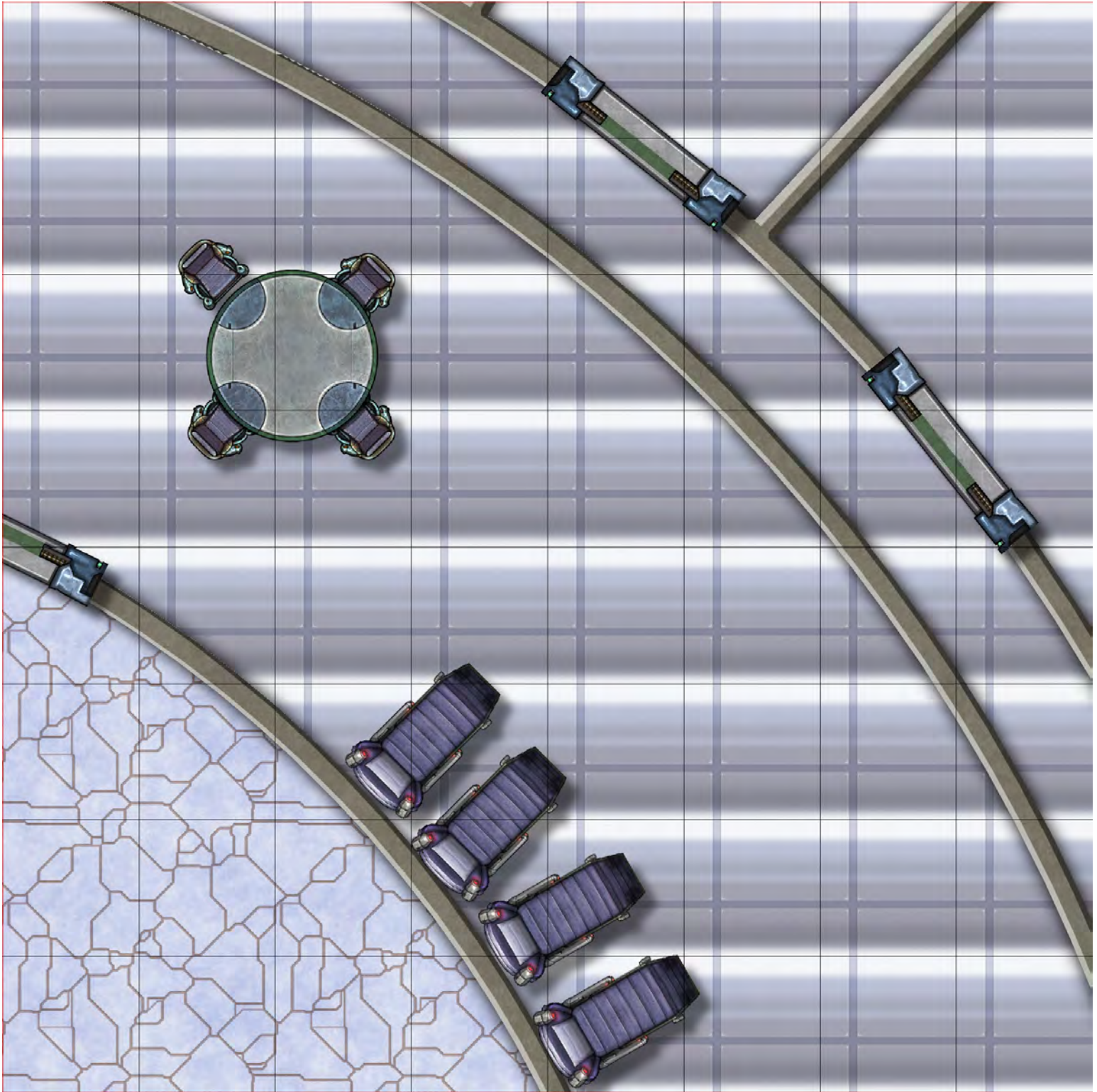

Bar B1

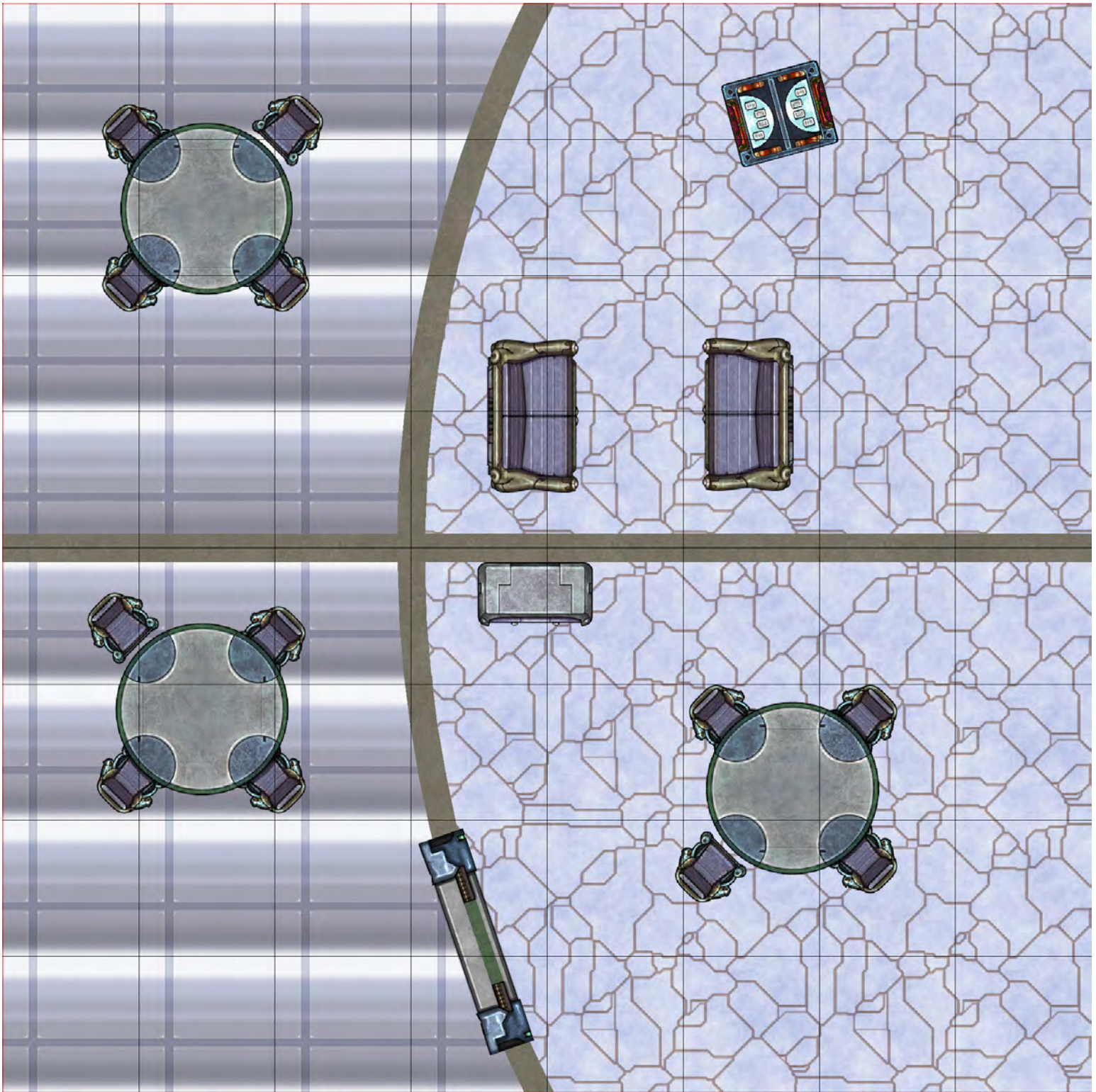

Bar B2

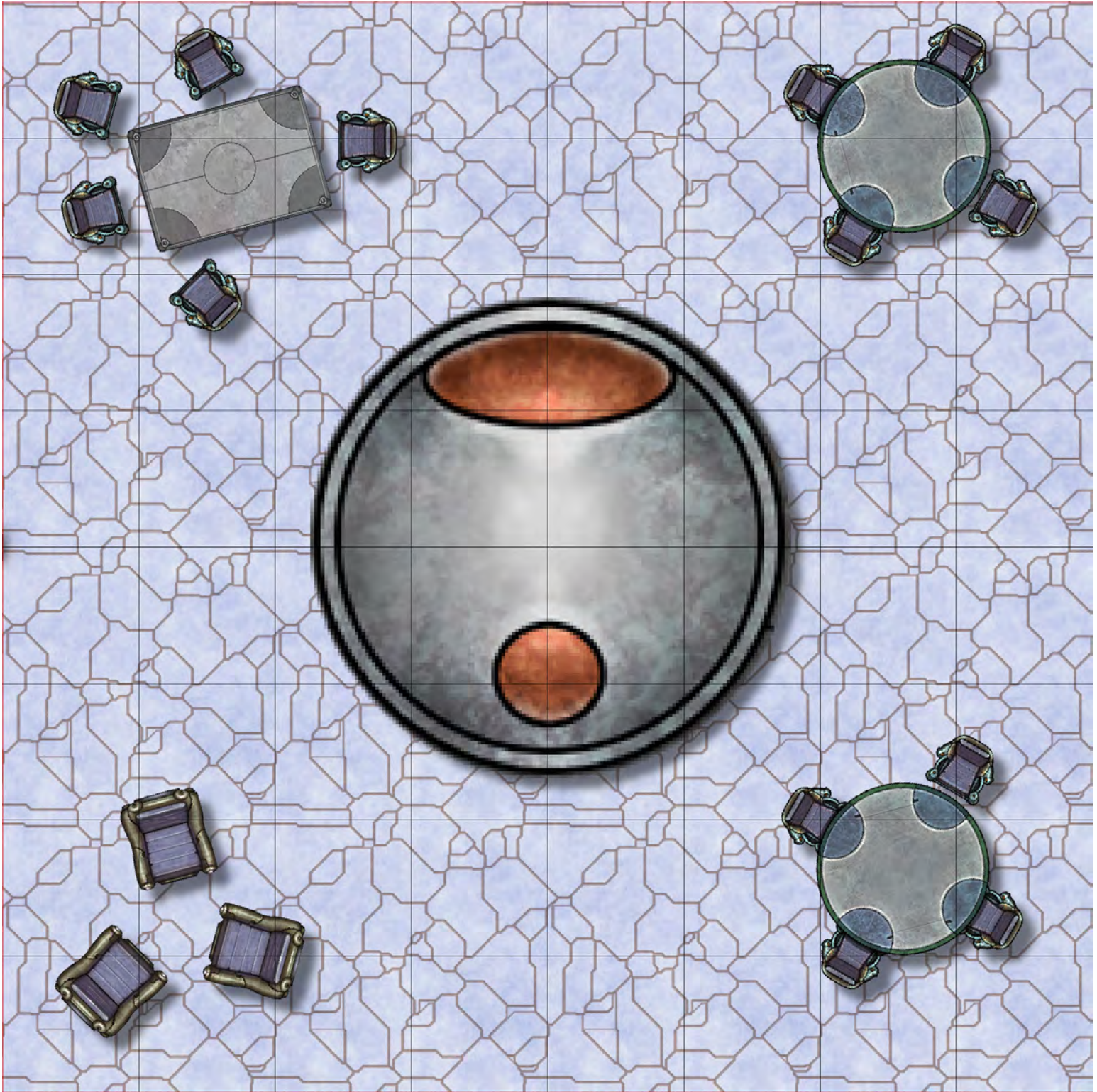

Bar B3

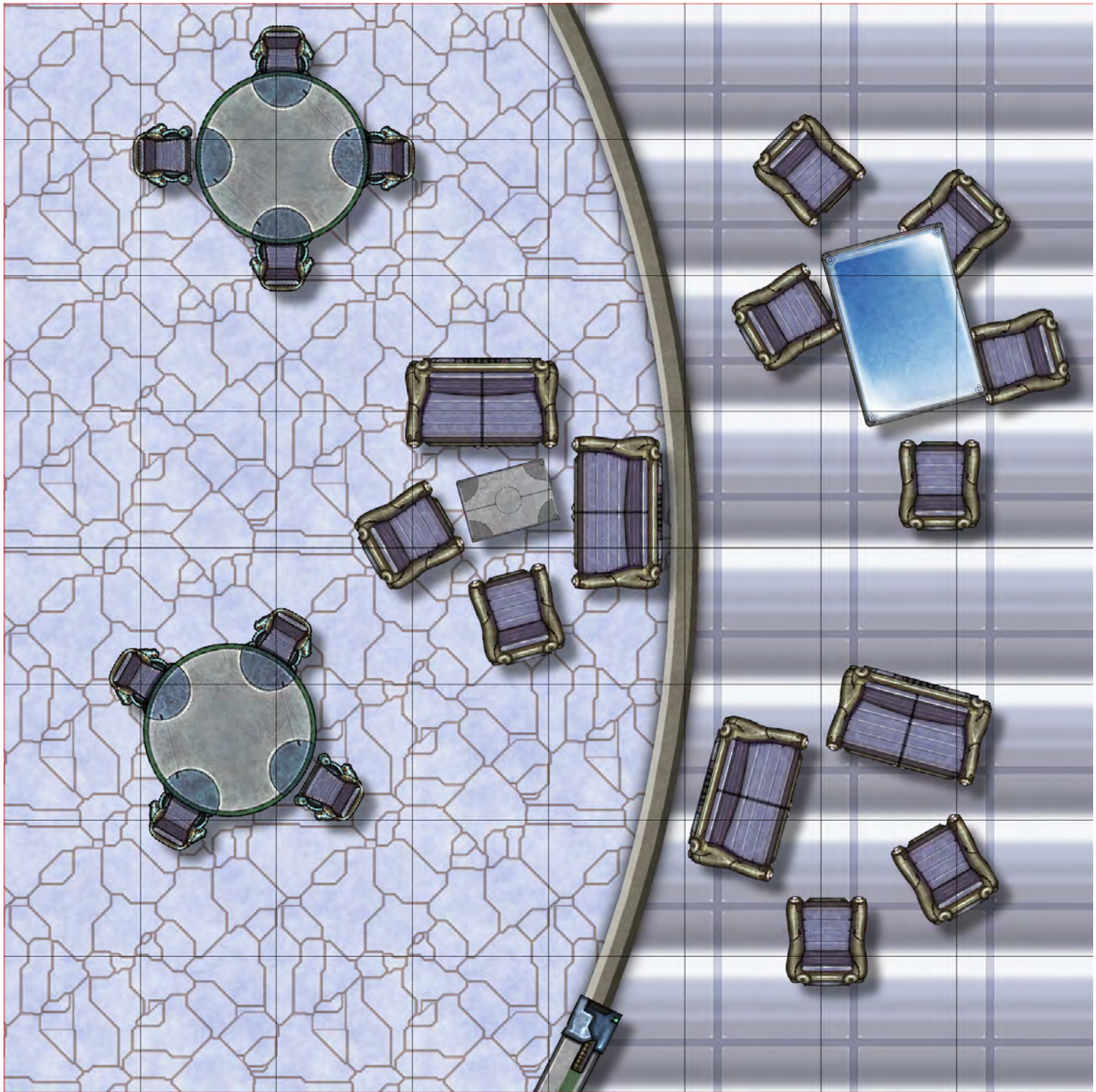

Bar C1

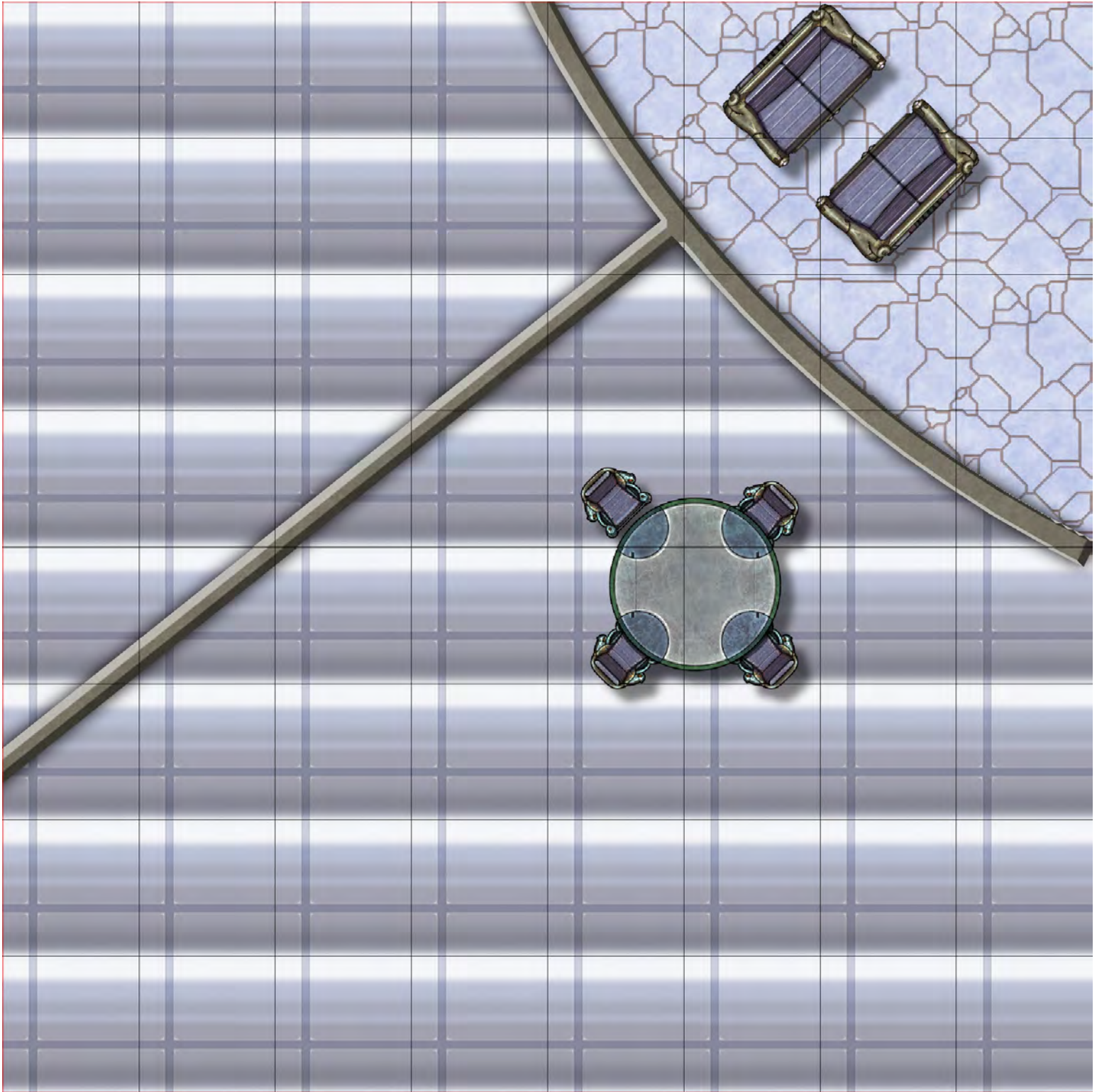

Bar C2

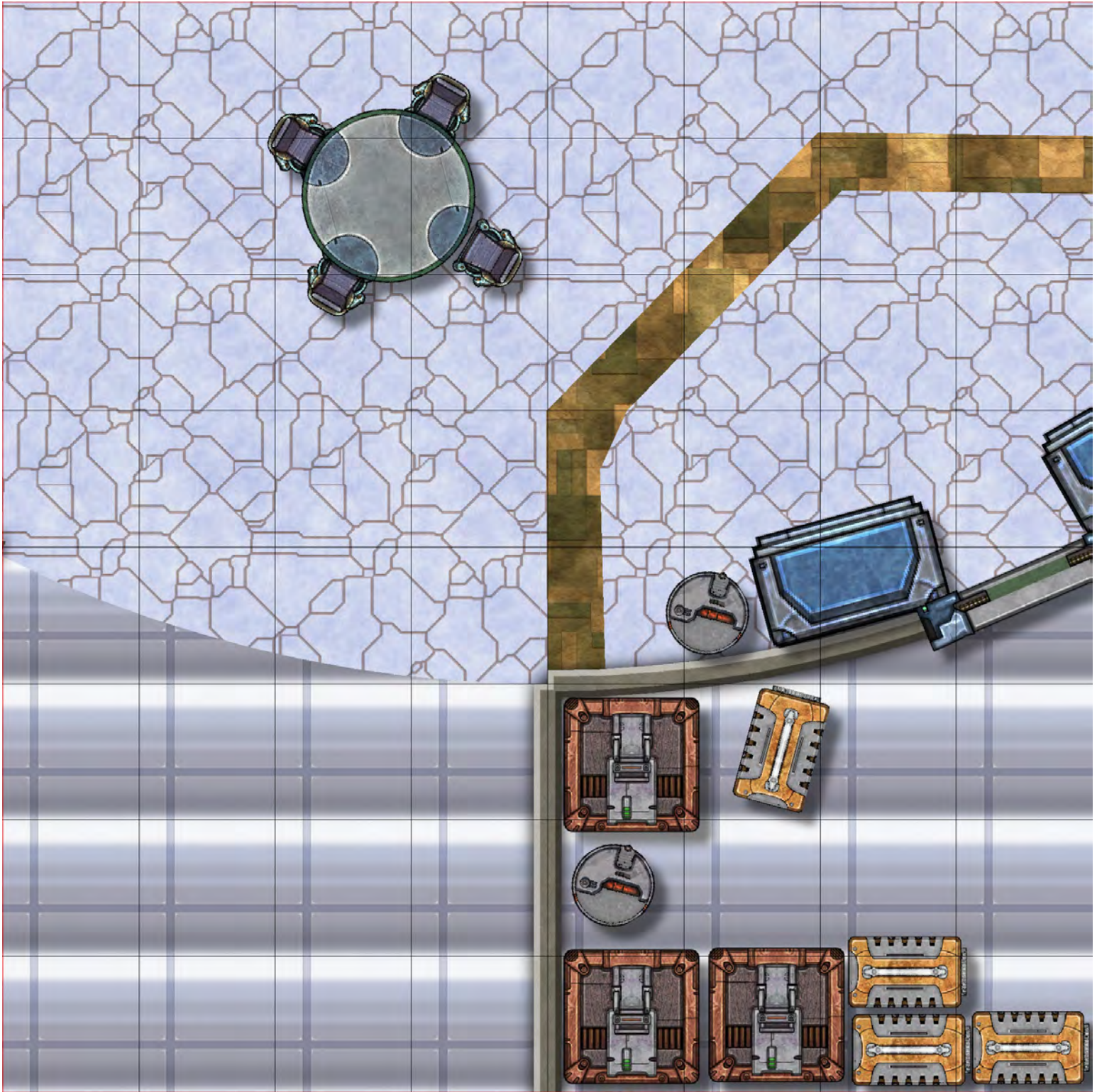

Bar C3

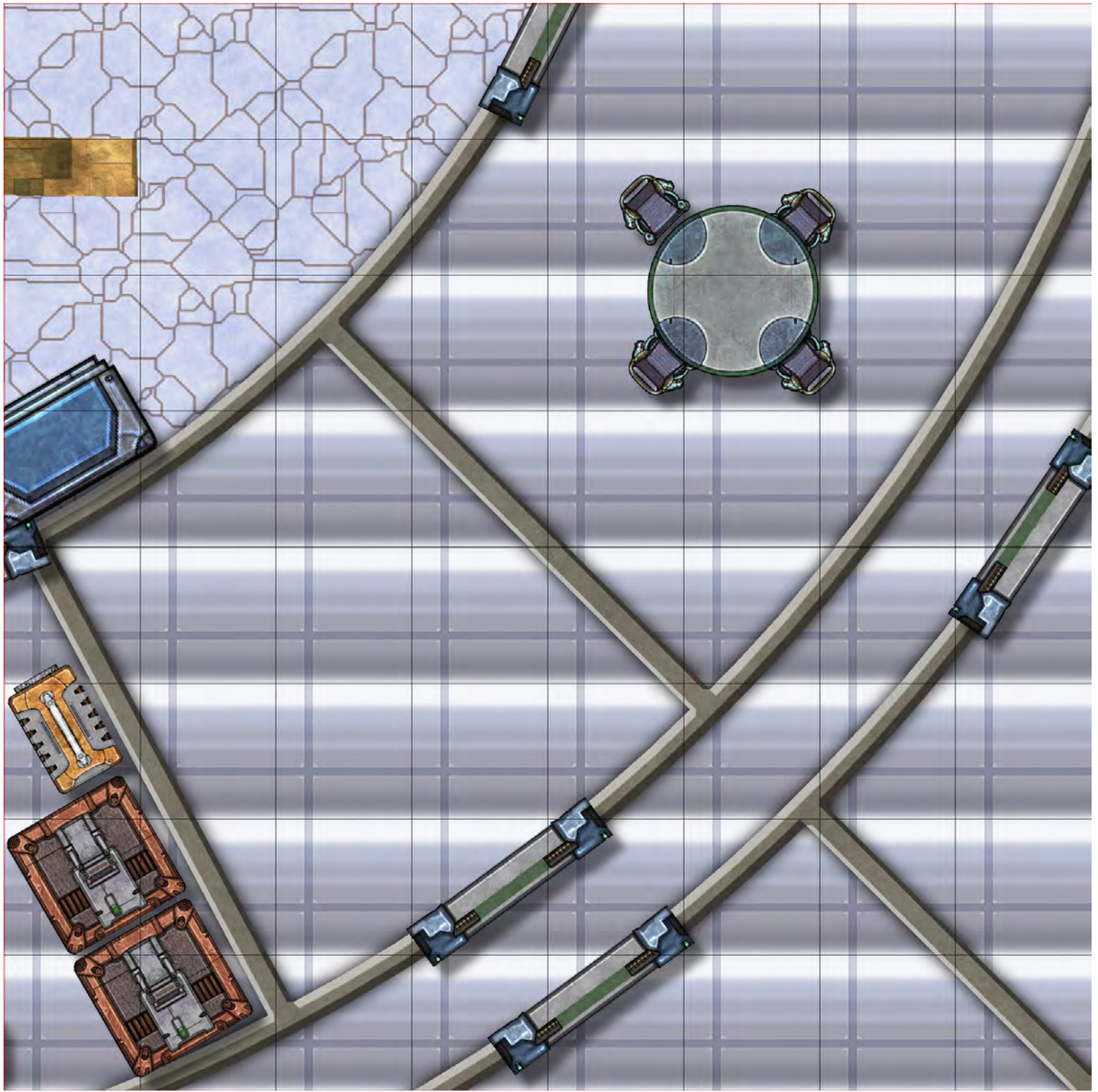

Chapel A1

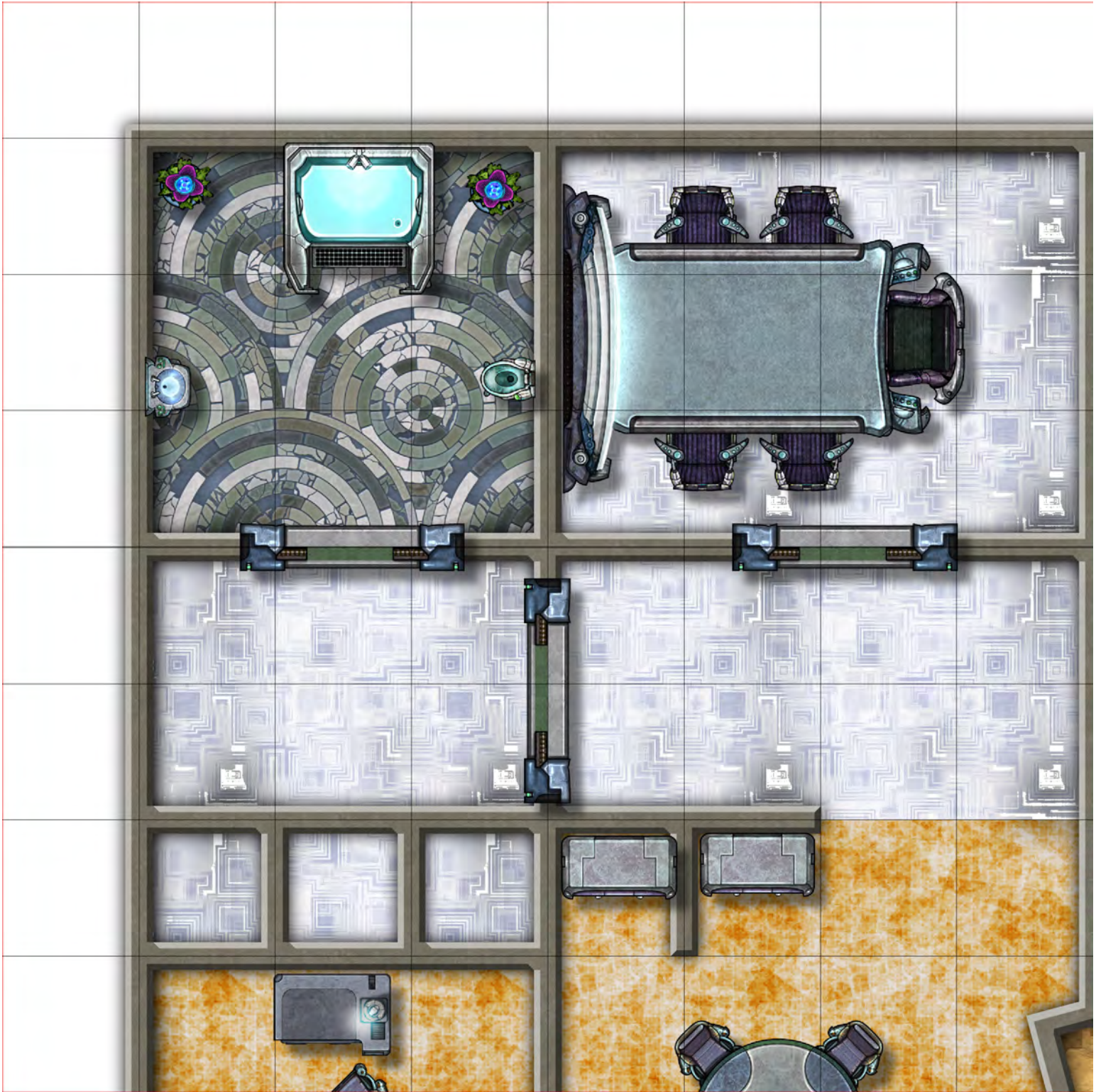

Chapel A2

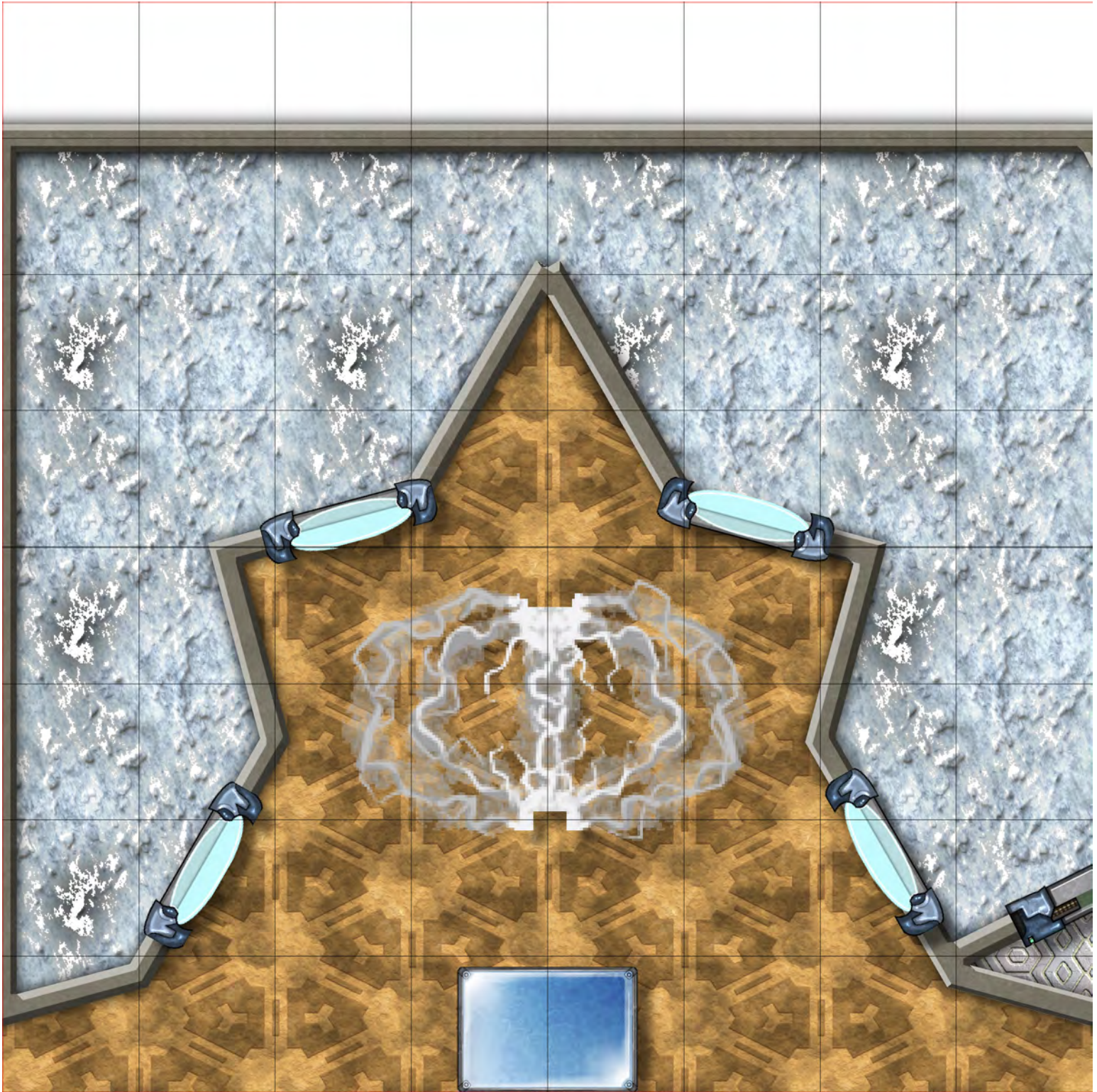

Chapel A3

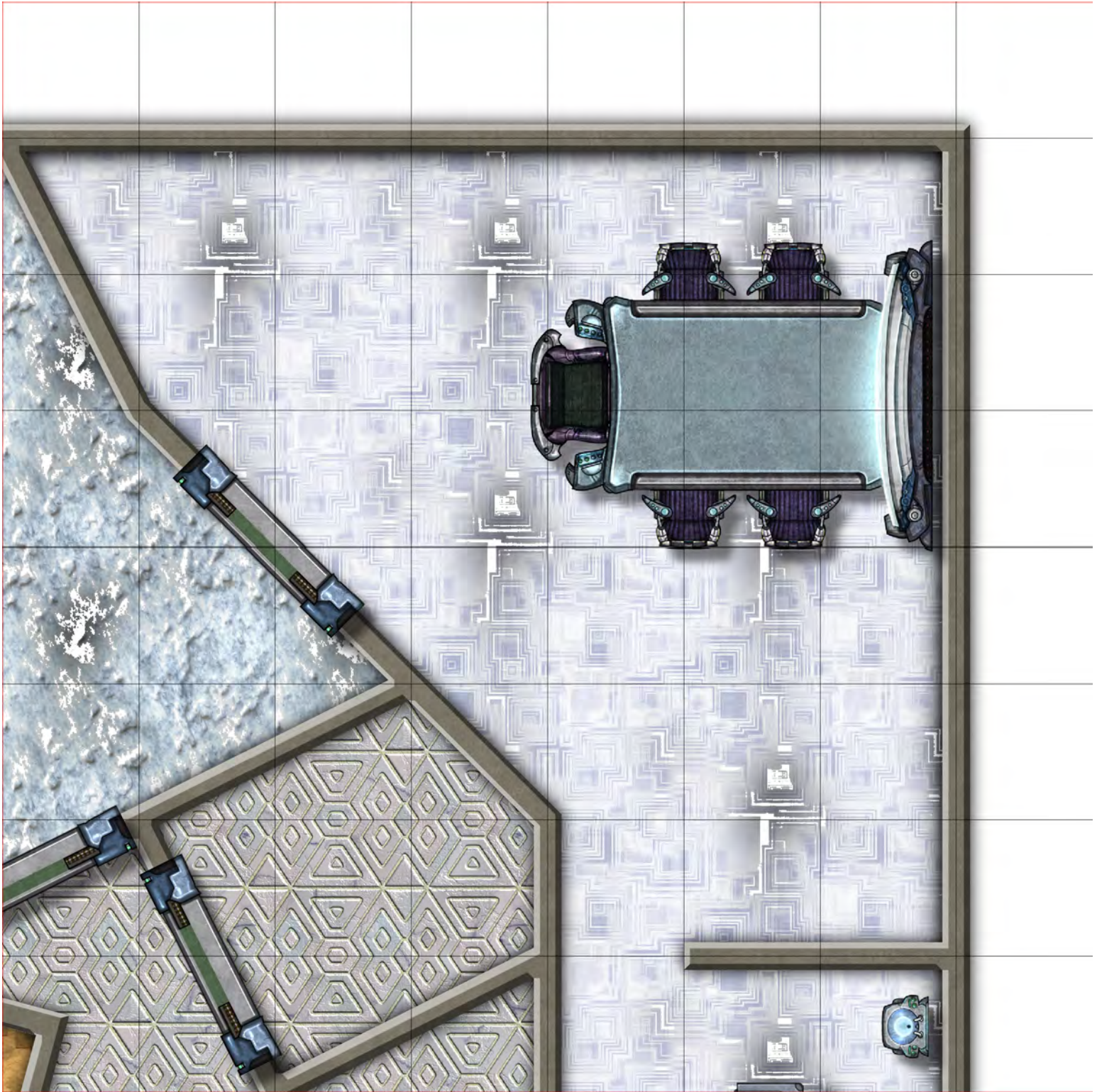

Chapel B1

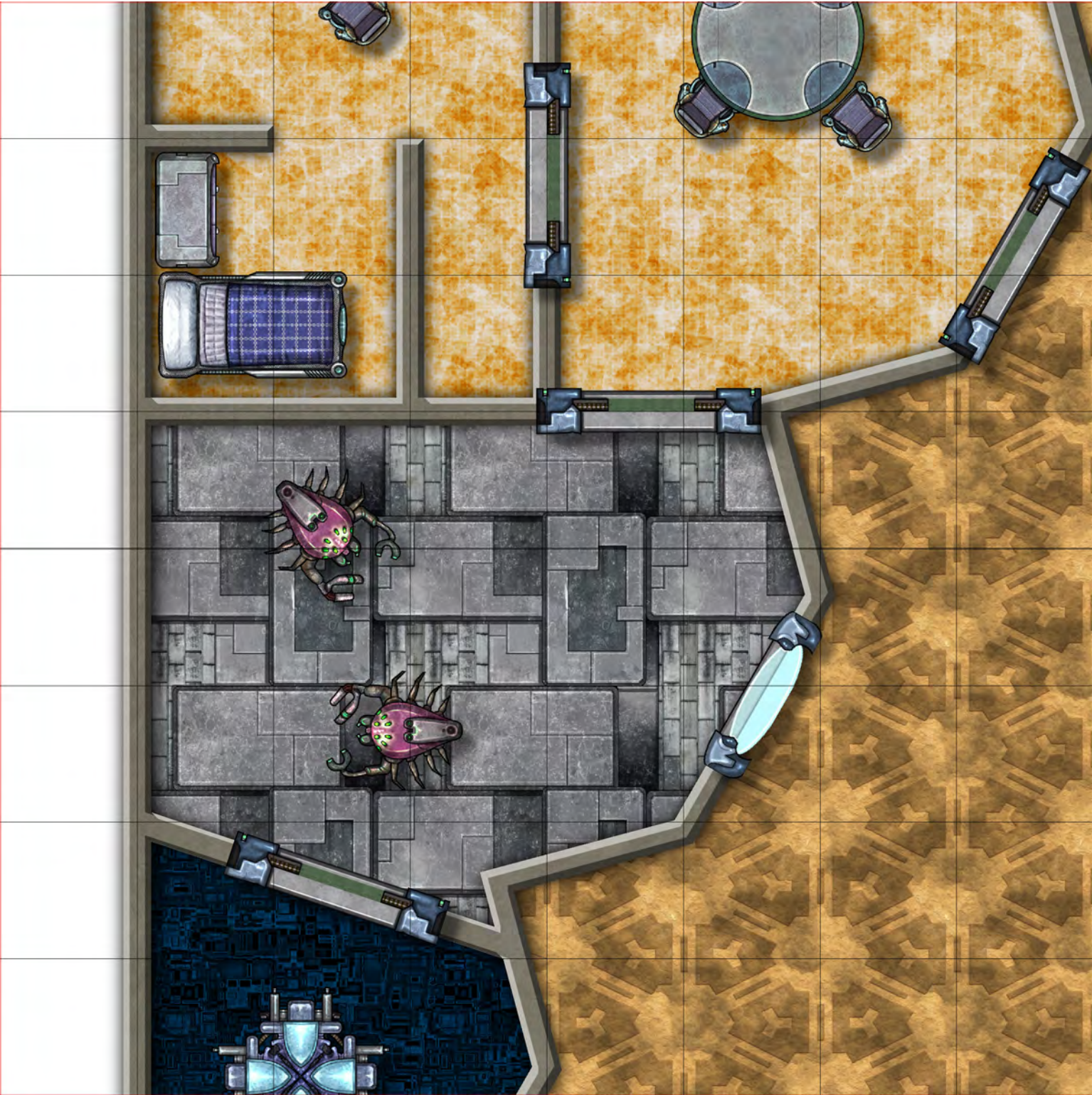

Chapel B2

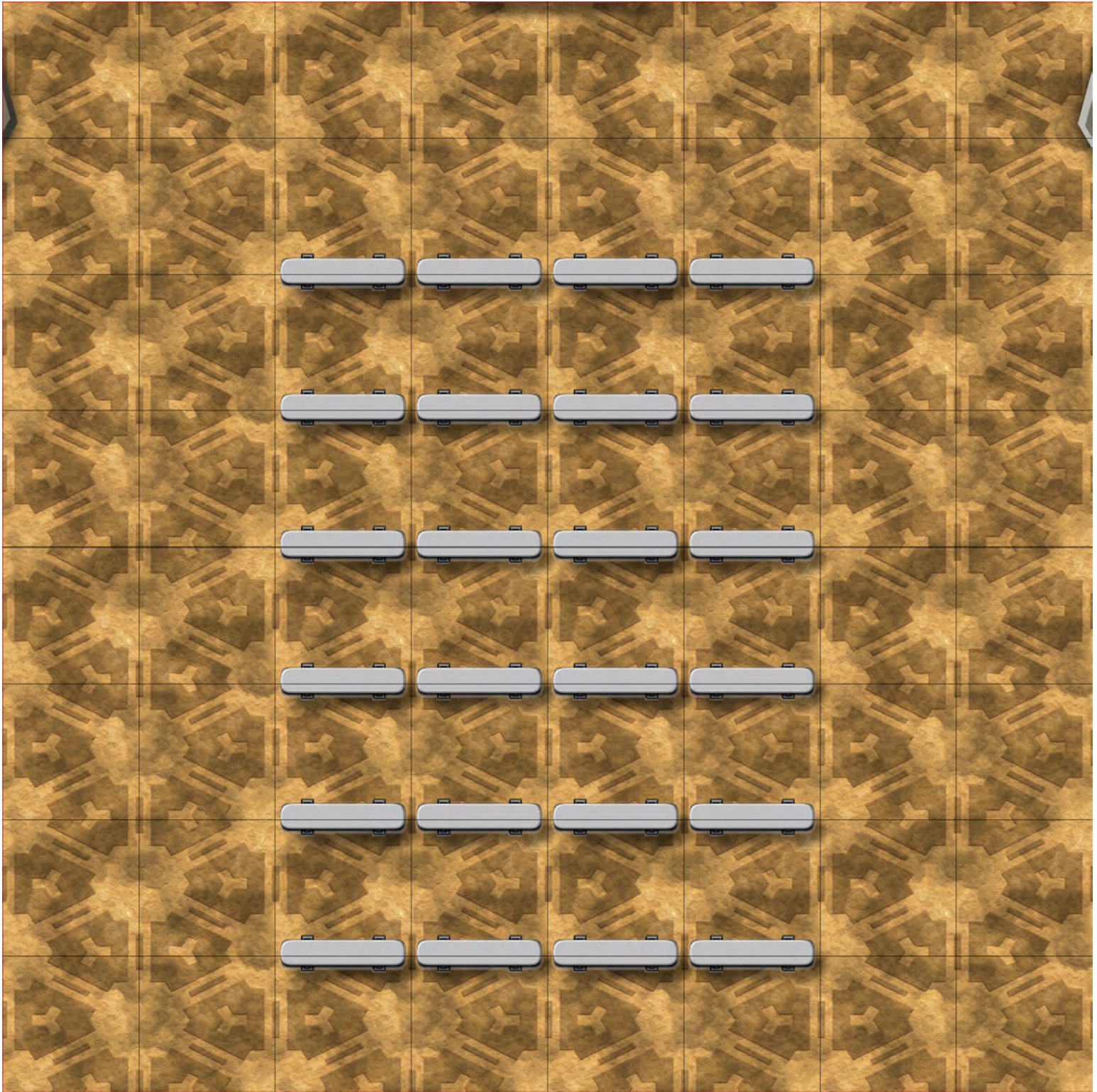

Chapel B3

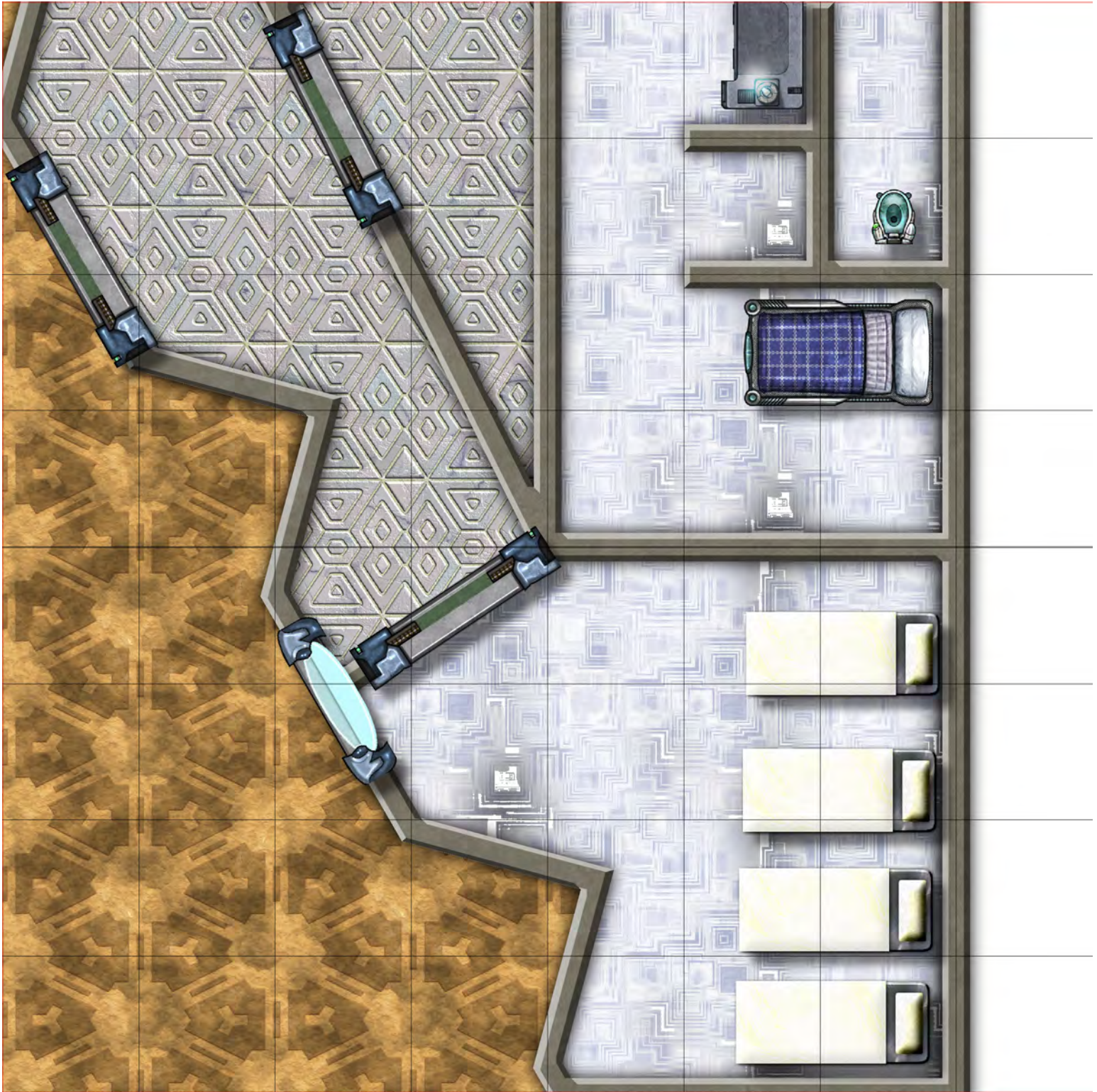

Chapel C1

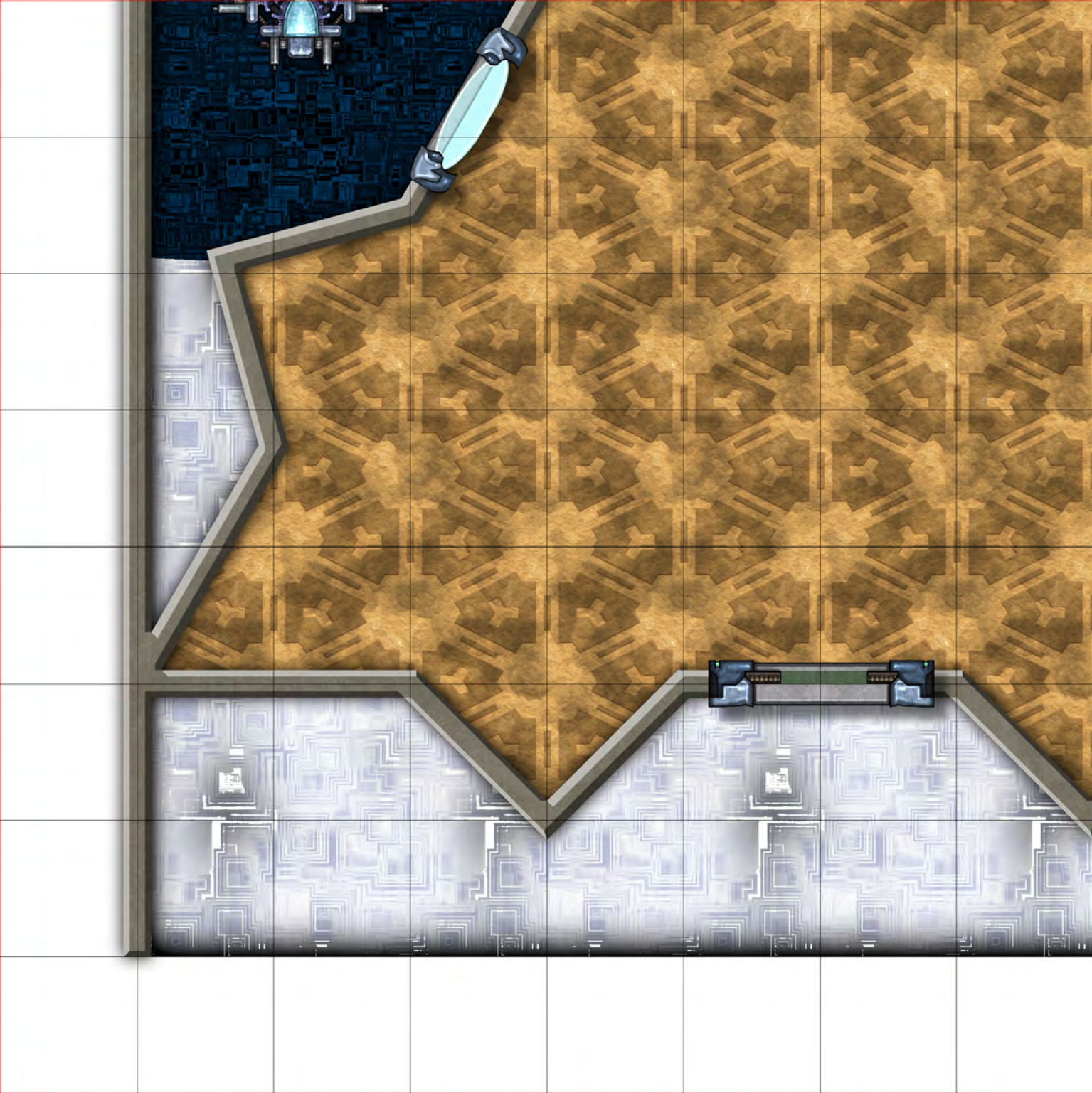

Chapel C2

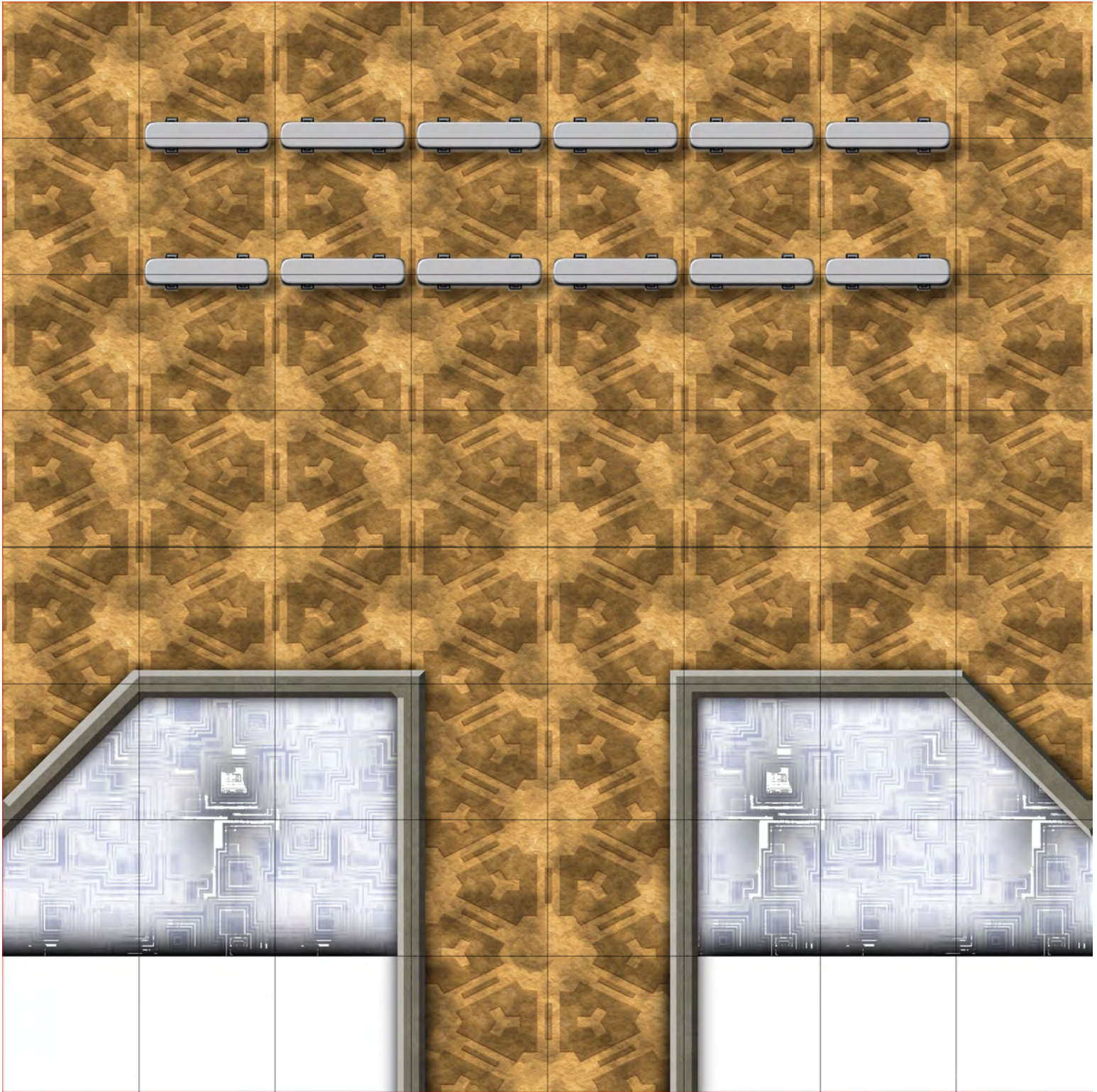

Chapel C3

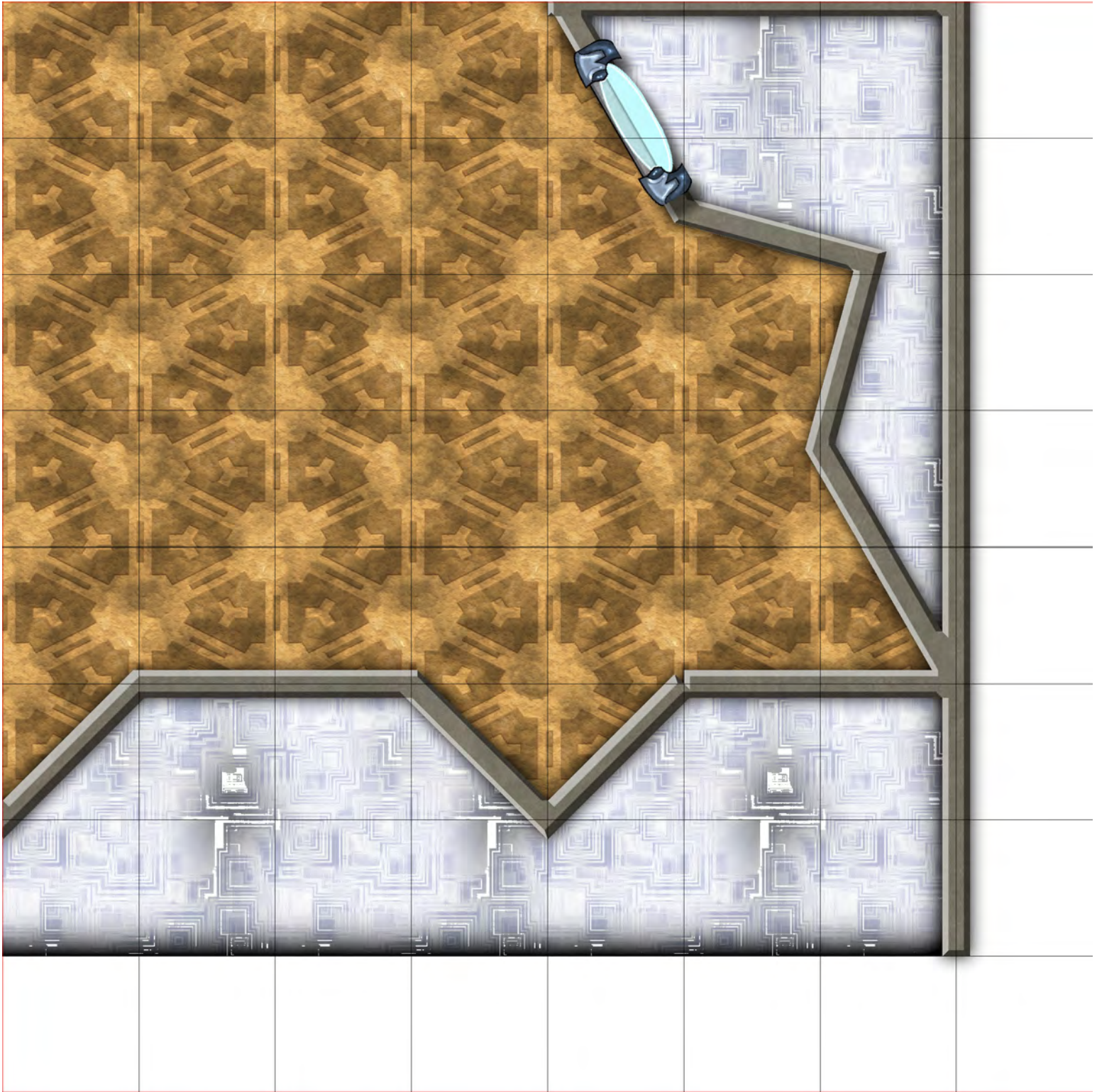

BUT WAIT... THERE'S MORE!



Join the Weavils' Journal and get free monthly products & adventures for your favorite games. Head over to the StoryWeaver website to sign up NOW!



Discuss your games with StoryWeaver's authors, and your fellow gamers. Keep an eye open for competitions too!



It's just like FaceBook, but with all those other Googly goodies. We also sometimes run demo and playtest games through Google Hangouts. Sweet.



Inspirational interviews with game developers, authors, artists, and other geeky types. Master Game Mastery with commentary from award-winning GMs and game designers. Videos for your games. And all sorts of other wonderful random stuff.



We tweet too! But not like a cute little sparrow... more like a seagull. Don't ask...